



Llywodraeth Cymru  
Welsh Government

# Woodland Creation Grant (Window 3) **Technical Guidance**

## **WOODLAND CREATION GRANT**

### **TECHNICAL SPECIFICATIONS FOR CAPITAL WORKS**

The Woodland Creation Grant (WCG) provides grants for tree planting and associated livestock and deer fencing, gates with 12 years of maintenance and premium payments. You need to have a verified Woodland Creation Plan (WCP), which has been written by Registered Woodland Planner (RWP), before you can apply for WCG funding.

The Capital Works included in the WCG Contract need to be completed in line with the quantity, location and timing as specified in the Contract. The following Technical Specifications provide the detail of how each Capital Work must be completed.

If any work claimed is found to have been carried out to a different standard, without the prior approval by Welsh Government, the project may be considered ineligible. This will result in claims being withheld (or recovered) with penalties applied in line with the scheme rules unless work is assessed to have been delivered to an equivalent standard.

You should note that certain works that you are required to undertake as part of your WCG Contract may require consents and permissions over and above those highlighted in these Technical Specifications before commencement of works within this Contract.

# CONTENTS

<b>1. GENERAL PLANTING GUIDANCE</b>	<b>4</b>
Planning-----	4
Timing -----	4
Ground Preparation-----	4
Tree Species-----	5
Buying trees and shrubs-----	5
Nursery Stock-----	5
Tree Size-----	5
Tree Handling-----	6
Tree planting-----	6
Tree protection -----	6
Open Space-----	7
Planting next to rivers, ponds, streams etc -----	7
Protection against Livestock-----	7
Maintenance Operations-----	7
Claiming the grant-----	8
<b>2. WOODLAND CATEGORY PLANTING REQUIREMENTS AND SPECIFICATION</b>	<b>9</b>
P001 - Agroforestry – Scattered Trees -----	9
Species Eligible - P001 - Agroforestry – Scattered Trees -----	12
P002 - Native Woodland - Biodiversity (1600)-----	13
P003 - Native Woodland – Carbon -----	14
P004 - Enhanced Mixed Woodland-----	15
P005 - Native Woodland - Biodiversity (1100)-----	16
<b>3. ASSOCIATED FENCING CAPITAL WORKS</b>	<b>17</b>
P595 - Post and Wire Fencing with Stock Netting-----	17
P518 - Deer fencing-----	19
<b>4. ASSOCIATED GATE CAPITAL WORKS</b>	<b>21</b>
P590 - Standard Gate (Metal)-----	21
P599 - Standard Gate (Hardwood) -----	21
P600 - Standard Gate (Softwood)-----	22
P516 - Timber Bridle Gate and Posts-----	23
P517 - Timber Kissing Gate and Posts-----	<b>Error! Bookmark not defined.</b>

## **1. GENERAL PLANTING GUIDANCE**

The following general guidance is applicable to all (WCG) Categories. Please note the specific requirements relating to **P001 – Agroforestry – Scattered Trees**

### **Planning**

You can only start to plant the trees when have the WCG contract has been agreed. You must follow your agreed WCP. When planning the tree planting, you will need to consider the purchase of trees and shrubs, availability of labour to do the planting, the type of site, weather and how long tree planting is likely to take. You will need to know when deadline is for claiming the grant. The WCG contract will have allocated a year for completion of the work, and you will need to note the deadline for submitting a claim.

### **Timing**

The planting season traditionally runs from 1 October to 31 March but with climate change, the season has been extended. Trees are usually planted over the colder months of the year. You should not plant when the ground is frozen.

### **Ground Preparation**

It is recommended to graze or mow the area of grassland immediately prior to planting, so it is easier to plant the trees. If there is a thick layer of dead material, it is more difficult to firm in the soil around the stem.

Ground preparation techniques such as screefing (cut away the turf to expose the soil), scarification and mounding before planting are key to good tree establishment. These are options which minimise soil carbon loss. When correctly undertaken, ground preparation will control vegetation and speed up the planting operation by providing a well worked site.

You will have the option to claim up to 15% of the WCG when you have completed your

ground preparation. These operations may be inspected by RPW before the payment is made.

### **Tree Species**

The trees species you will be planting will depend on the selected categories in the WCP. No ash or larch must be included in any planting mixture for woodlands *due to Ash dieback disease (Chalara fraxinea), and Phytophthora Ramorum.*

### **Buying trees and shrubs**

Where possible, use UK tree nurseries to minimise the risk of importing tree pests and diseases. Plant Healthy tree nurseries [Directory - Plant Healthy](#) – have been certified to demonstrate that the trees and shrubs have been grown in the UK and the biosecurity risk of importing pests and diseases is minimised. You can collect the seeds yourself and grow onto trees and shrubs as long as you comply with the WCP.

### **Nursery Stock**

**Bare Root** – trees are lifted from the ground with bare roots and packaged together in bundles. Bare rooted stock is used most regularly for new planting but needs to be stored and handled carefully so that the roots do not dry out.

**Cell Grown (Plugs)** – grown in plastic trays which create a narrow plug of fine roots and soil. These trees allow the planting season to be extended at either end as the roots can grow within the soil plug and avoid damage during planting.

**Pot Grown** – grown in an individual plant pots and are usually shrubs such as holly.

### **Tree Size**

Smaller planting stock is usually best for tree planting because of the “root-to-shoot” ratio, meaning that there will be a lot of roots and relatively few branches and leaves.

Consequently, the trees are more likely to establish quickly and successfully, and once established they will be more firmly rooted and will grow faster, than trees which are planted out as larger stock.

You should generally aim to buy trees and shrubs between 20 and 60cm. Avoid larger

and more expensive trees and shrubs e.g. 120-150cm trees and 60-90cm shrubs.

### **Tree Handling**

Young trees are fragile and vulnerable to damage from rough handling between the nursery and their final planting site. It's advisable to get the trees delivered to the site where they are to be used or as close to it as possible. This avoids time-consuming (and exhausting) double-handling of trees and greatly reduces the chance of damage.

Be on hand when plants arrive so that you can ensure they are in good physical condition. ***Keep the roots of bare rooted stock covered at all times before planting to prevent damage and drying out.*** Whilst cold is unlikely to be harmful, hot sun and any form of drying such as an east wind, can very quickly cause damage or kill the plants. If immediate planting is not possible, dig a trench before delivery and store plants in this with the roots covered so they are kept moist and cool. Protect the plants from animals, including rabbits and hares.

### **Tree planting**

Make sure you follow the WCP. You can either employ a contractor to carry out the tree planting or carry out the planting yourself. You may want to ask the RWP who wrote the WCP for advice on the tree planting.

### **Tree protection**

Most planting sites have rabbits, hares, deer or voles present, and it is advisable to protect broadleaves with tree shelters to prevent damage. Conifers can establish without additional protection. There are many different types of tree guards available, from light spiral guards secured with canes, to solid plastic shelters which require stakes and ties. Tree shelters can boost the early growth of trees, make maintenance easier and ensure the trees are not damaged by mammals or bracken. Your RWP will advise you of the type of tree protection you need in the WCP.

## **Open Space**

Scattered, unplantable open ground can be included within the planting area up to a total of 15% of the total area and individual blocks of unplantable open ground can be up to 0.5ha. Individual areas of open ground over 0.5Ha must be excluded from the planting scheme. You will need to alter the tree spacing in parts of the site to account for un-plantable ground to ensure the required number of trees in the contract are planted.

## **Planting next to rivers, ponds, streams etc**

Aim for a mix of shaded and lightly shaded habitat within the riparian zone – around 50% canopy cover on average but guided by local circumstances and the requirements of priority species. No more than 10% alder should be planted in riparian areas (e.g. next to ponds, rivers and stream etc) in line with the UK Forestry Standard.

## **Protection against Livestock**

New planting under WCG must be protected from domestic animals and deer by using appropriate boundary fencing for at least 12 years from the first woodland creation maintenance claim.

## **Maintenance Operations**

### **Maintenance of trees and shrubs**

Weed control around trees is crucial, as there will be competition for water and nutrients until the trees establish. You need to control the vegetation around the trees and shrubs for a minimum of 3 years until the trees outgrow the surrounding vegetation. Tall vegetation like bracken or bramble can cause physical damage to the trees and cutting by hand or mechanically is normally required. Cutting or strimming the grass simply makes it more vigorous.

Spot weeding with a suitable herbicide is the most effective method of control. Only properly licensed chemical products can be used and applied by qualified operators. Plastic, cardboard, or woven mulch mats can be used as an alternative to chemical weed

control. The better the quality of the initial planting, protection and maintenance, the more likely that the trees will establish quickly and successfully.

### **Replacement trees (Beating Up)**

Beating up is the practice of replacing trees and shrubs to ensure there is 100% tree survival by the end of the WCG contract (13 years). A planting site should be assessed for losses towards the end of the summer annually. Any dead trees must be replaced in the following autumn or spring. Look for any pattern to the losses, in terms of particular areas and species. If losses are greater than 10-15% and there is no obvious cause, you should consult your plant supplier or seek professional forestry advice.

### **Tree Shelters**

These need to be checked regularly to make sure they are secure. Vegetation will often grow up into tubes and guards and tubes need to be kept in contact with the ground to avoid rabbits and small mammals' access to the stems. Although many products are biodegradable, they can have a negative effect on the growth and stability of the trees if left and should be removed as soon as they are not required.

### **Claiming the grant**

You claim the tree planting, fencing and gates grants after the work has been completed through your RPW online account.

The annual maintenance and premium are claimed through the Single Application Form (SAF) through your RPW online account in the May a year after the tree planting has been completed.



## **2. WOODLAND CATEGORY PLANTING REQUIREMENTS AND SPECIFICATION**

### **P001 - Agroforestry – Scattered Trees**

This technical note describes the minimum standard of work required in order to receive payments for 'Agroforestry – Scattered Trees'. Where there are local traditional methods or styles that vary from this standard, these can be used. Any significant variation must be approved by the Welsh Government.

#### **Specification**

- 80 trees per hectare
- Individual tree crates
- Not eligible for Woodland Creation Premium payment

#### **Grazing Level**

The minimum stocking level for the area of scattered planting is 0.4 Livestock Units per hectare at any time between 1 May and 30 September.

A stocking diary must be kept details the numbers of stock grazing the area at any time.

#### **Tree Planting**

The tree planted must be a large whip over 1.5 metres in size and a suitable sized tree shelter to protect against mammal damage.

The species to be planted are listed below.

#### **Tree Guard**

##### **Height and Positioning of Guards**

All guards constructed from timber rails must be at least 1.2 m high and set at least 1m from the tree to protect against sheep (or 1.5m to protect against cattle and horses.)

## **Construction**

Use a combination of vertical posts and horizontal rails to build a rigid structure. Fix wire netting around it to prevent access by livestock. The horizontal rails will prevent the posts from being loosened. A variety of stock might have access to the parkland over time so the guard must be strong enough to withstand the worst case scenario. Do not try to increase the distance of the top rail from the tree by slanting the posts outwards. This will make it difficult to fix the netting securely in place.

It is not necessary to top the enclosure with barbed wire as this is unlikely to stop animals leaning over and you will make it more difficult to get into the enclosure to tend the tree. Barbed wire may also cause injury to both you and your livestock.

## **Design**

The guard must be square or rectangular enclosures are the preferred design. Each of the 4 corner posts should have a minimum diameter of 10cm x 10cm. At least four wooden rails with a minimum diameter of 10cm x 5cm should be fixed to the outside of the posts. Galvanised netting should then be fixed around the outside of the structure and held in place with galvanised staples. An additional set of rails may also be placed mid way up the posts to provide additional strength. All timbers, netting and staples must consist of new materials. Timber must comprise either pressure treated softwood or hardwood.

## Parkland Tree Guards

### Post and Rail Type

#### a) Suitable for use with sheep

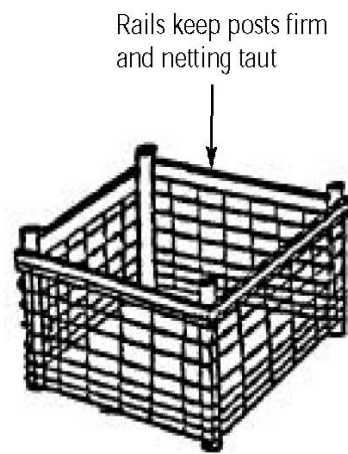
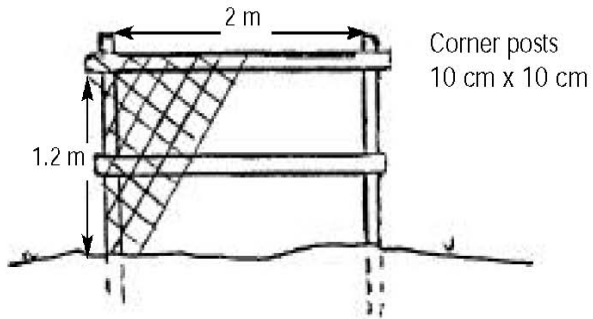

#### b) Suitable for use with horses and cattle

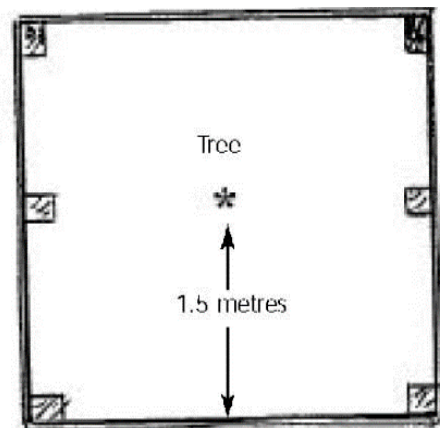
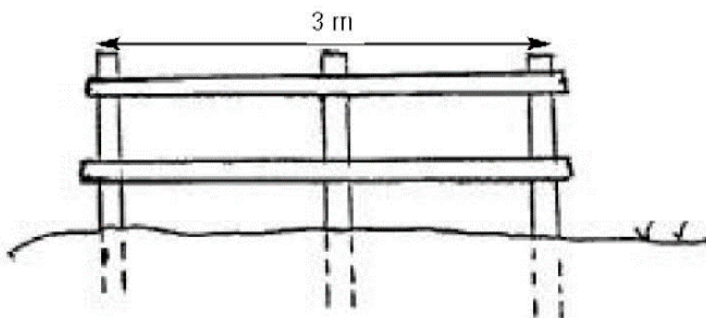

## Species Eligible - P001 - Agroforestry – Scattered Trees

### Trees

Common Alder	Sycamore
Crab apple	Sweet Chestnut
Silver Birch	Evergreen Oak
Downy Birch	Horse Chestnut
Beech (S of the A40)	Rock Whitebeam
Bird Cherry	Spindle
Wild Cherry (Gean)	Goat Willow
Wych Elm	Common Sallow
Common (English) Elm	Purple Osier
Hawthorn	Common Osier
Hazel	Eared Willow
Holly	Blackthorn
Small leaved Lime	
Large Leaved Lime	
Field Maple	
Pedunculata Oak	
Sessile Oak	
Scots Pine	
Aspen	
Black Poplar	
Rowan	
Whitebeam	
Service Tree	
Wild Service Tree	
Crack Willow	
White Willow	
Almond leaved Willow	
Yew	
Walnut	

## **P002 - Native Woodland - Biodiversity (1600)**

This technical note describes the minimum standard of work required in order to receive payment for new planting of native broadleaved species under the capital works Woodland Category 'Native Woodland – Biodiversity'.

**You must also refer to the detailed planting requirements forming part of this contract which are shown in Section 1 General Planting Requirements.**

### **Planting Requirements**

This capital works option requires native tree species to be planted.

Trees can be planted in a clumped distribution with variable spacing e.g the planting should be made up of groups of between 5 to 20 trees of the same species.

### **Specification**

- Native species - mix should be site native and largely conform to Habitat Action Plan types (for example upland oak, lowland mixed deciduous woods), however, local conditions may necessitate some variation from these.
- Suitable provenance planting stock
- Maximum 30% woody shrubs allowed
- Clumped distribution of species with variable spacing
- Stocking density 1,600/ha
- Exclude Livestock

Planting under this option requires - 1,600 tree/Ha which equates to 2.5m spacing between trees although the spacing can be clumped. You may need to increase the stems per hectare in parts of the site to take account of features such as rocky outcrops or unplantable open ground.

A minimum of 1600 stems per hectare must be planted with 100% establishment for 12 years following the year in which the trees were planted.

## **P003 - Native Woodland – Carbon**

This technical note describes the minimum standard of work required in order to receive payment for new planting of native broadleaved species under the capital works planting option 'Native Woodland – Carbon'.

**You must also refer to the detailed planting requirements forming part of this contract which are shown in Section 1 General Planting Requirements.**

### **Planting Requirements**

This capital works option requires native tree species to be planted.

Trees can be planted in a clumped distribution with variable spacing e.g. the planting should be made up of groups of between 5 to 20 trees the same species.

### **Specification**

- Native species mixture
- Maximum 30% woody shrubs allowed
- Stocking density 2,500/ha
- Exclude Livestock

Planting under this option requires 2,500 tree/Ha which equates to 2.0m spacing between trees. You may need to increase the stems per hectare in parts of the site to take account of features such as rocky outcrops or unplantable open ground.

A minimum of 2,500 stems per hectare must be planted with 100% establishment for 12 years following the year in which the trees were planted.

## **P004 - Enhanced Mixed Woodland**

This technical note describes the minimum standard of work required in order to receive payment is for new planting of native broadleaved species under the capital works planting option 'Enhanced Mixed Woodland'.

**You must also refer to the detailed planting requirements forming part of this contract which are shown in Section 1 General Planting Requirements.**

### **Planting Requirements**

This capital works option requires a mixture of tree species to be planted.

### **Specification**

- Minimum of 5 major species (at least 10% of each)
- Minimum of 25% broadleaves inclusive of woody shrub element or 30% if the planting area is below the upper limit of enclosure and larger than 30 hectares
- Maximum 10% woody shrub element
- No more than 50% of a single species
- Stocking density 2,500/ha
- Exclude livestock

Planting under this option requires 2,500 tree/Ha which equates to 2.0m spacing between trees. You may need to increase the stems per hectare in parts of the site to take account of features such as rocky outcrops or unplatable open areas.

A minimum of 2500 stems per hectare must be planted and be alive or have achieved canopy closure for 12 years following the year in which the trees were planted.

## **P005 - Native Woodland - Biodiversity (1100)**

This technical note describes the minimum standard of work required in order to receive payment for new planting of native broadleaved species under the capital works planting option 'Native Woodland – Biodiversity'.

**You must also refer to the detailed planting requirements forming part of this contract which are shown in Section 1 General Planting Requirements.**

### **Planting Requirements**

This capital works option requires native tree species to be planted.

Trees must be planted in a clumped distribution with variable spacing e.g the planting should be made up of groups of between 5 to 20 trees of the same species.

### **Specification**

- Native species - mix should be site native and largely conform to Habitat Action Plan types (for example upland oak, lowland mixed deciduous woods), however, local conditions may necessitate some variation from these.
- Suitable provenance planting stock
- Maximum 30% woody shrubs allowed
- Clumped distribution of species with variable spacing
- Stocking density 1,100/ha
- Exclude Livestock

Planting under this option requires - 1,100 tree/Ha which equates to 2.5m spacing between trees. You may need to increase the stems per hectare in parts of the site to take account of features such as unplanted ground or riparian zones. A minimum of 1100 stems per hectare must be planted and be alive or have achieved canopy closure for 12 years following the year in which the trees were planted.



### **3. ASSOCIATED FENCING CAPITAL WORKS**

#### **P595 - Post and Wire Fencing with Stock Netting**

These are the minimum standards of work required in order to be eligible to receive payment for 'Post and Wire Fencing with Stock Netting'.

You must adhere to the following:

- Ensure that you have obtained, and adhere to any licences, consents or permissions that are needed.
- Use fencing timber comprising either hardwood or pressure treated softwood.
- Ensure that timbers, wire, netting and galvanised staples consist of new materials.
- Use straining posts that are a minimum of 12.5cm cross section and at least 2m long. Straining posts must be set into the ground at a sufficient depth to ensure stability. Straining posts must be placed at either end of the fence line and at centres of 100m or less, as well as at every horizontal or vertical change of direction.
- Attach struts at each end of the fence line and at all changes of slope and direction. Struts must have a top diameter of at least 6.5cm and must be supported to prevent them splaying outwards. Use intermediate posts that are at least 6.5cm diameter (round posts and sawn timber) and at least 1.7m long. Half round posts are acceptable provided they measure at least 6.5cm from the midpoint of the sawn side to the midpoint of the round side. Intermediate posts must be set at centres of 3m or less.
- Attach netting to posts with galvanised staples.
- Attach wire to posts with galvanised staples with the distance from the ground to the top wire no less than 1.05m. In cases where there is heavy pressure from sheep or cattle, a second line wire on top of the netting as well as an additional wire at the bottom should be added. The top wires of any fencing erected next to public access routes must consist of plain wire or an additional line of plain wire must be affixed to the outside of the posts closest to the route in question.

- Ensure that the new fencing conforms to British Standards 1722 and 4102, as amended.
- Do not use trees and shrubs as strainers or fencing posts, or attach wire, staples or netting to them.

Requirements and guidance in addition to the specifications above:

- Best practice is to set the straining posts at least 1m into the ground to ensure stability.
- Diagonal struts must be supported with either a base plate or a suitably positioned intermediate post to prevent them splaying outwards.
- Ensure that you have the appropriate Flood Risk Activity Permit if you are planting or fencing near a main river, flood plain or flood defence structure. Alternatively, ensure you have the appropriate Ordinary Water Course Consent if you are carrying out works near an ordinary water course. What may be considered a ditch may be an ordinary watercourse, so consent may be required. As such, the permit/consent (or confirmation that a permit/consent is not needed) should be retained and made available on request. See Terms and Conditions for more details.

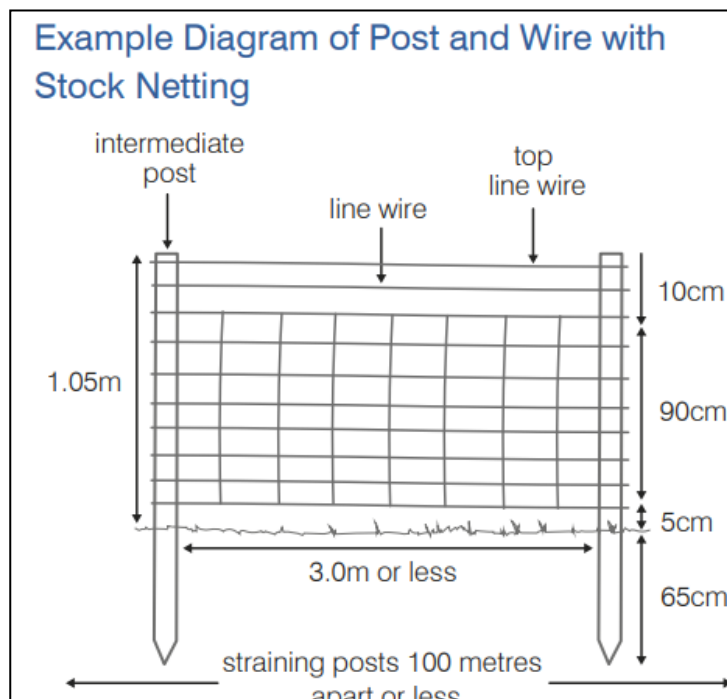

## **P518 - Deer fencing**

These are the minimum standards of work required in order to be eligible to receive payments for deer fencing.

Fencing timber must comprise either hardwood produced from Welsh woodlands or pressure treated softwood. A minimum life of 10 years is required for all timbers used.

Trees and shrubs must not be used as strainers or fencing posts, nor may they be used to support fencing wire, staples or netting. Fencing timbers, line wire, netting and staples used to construct approved fence lines must always consist of new materials. The standard payments include an allowance for the dismantling, removal and safe disposal of existing fences. All materials and construction standards must also conform to the following detailed specifications in addition to British Standards 1722 and 4102:

### **Materials and Construction**

<b>Straining posts</b>	3m x 15cm top diameter minimum	10ft x 6"
<b>Struts</b>	2.75m x 10-13cm top diameter round timber	9ft x 4-5"
<b>Intermediate posts</b>	2.75m x 8-10cm top diameter round timber	9ft x 3-4"
<b>Netting</b>	Either High Tensile type Or Light Weight High Tensile type	HT/13/190/15 LHT/13/190/15
<b>Top wire</b>	1 x 12 ½ g high tensile plain wire	
<b>Line wire</b>	3 x 12 ½ g high tensile plain wire	
<b>Staples</b>	4cm (1 ½ ") 8g	
<b>Finished height</b>	1.9m – 2m (6ft4" – 6ft 6")	

### **Construction**

Strainer posts to be situated at change of direction (either horizontal or vertical) or maximum 200m (ca. 600ft) on straight run. Dug or driven a minimum 90cm (3ft) into

the ground. The strainer struts to be notched and nailed to straining posts stabilised with a sawn rail thrust plate of 50cm x 38cm x 76cm (1ft 9" x 1½" x 3"). Intermediate to be spaced at 5m (16ft 6") intervals maximum.

The netting must be properly strained and fixed to give a maximum gap of 5cm (2") between the bottom of the net and the ground. A single top wire to be set 10cm (4") above the top of the net and the ground. The line wires to be set such that the bottom strand runs along the bottom of the netting; the middle strand runs at a height of 1m (3ft 4") from ground level and the top strand to run along the top of the netting. All line wires to be fixed securely to the netting with pig rings or lashing rods.

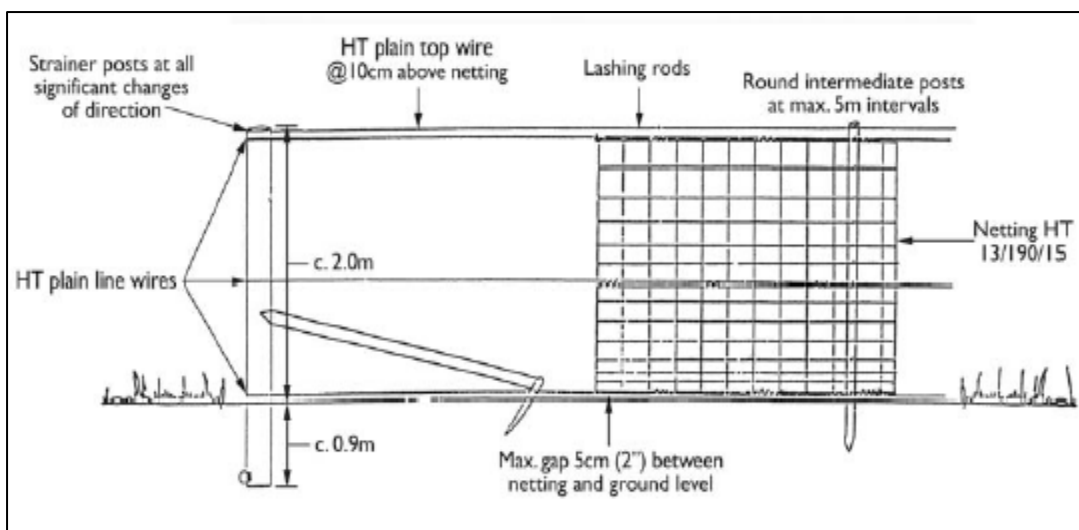

## **4. ASSOCIATED GATE CAPITAL WORKS**

### **P590 - Standard Gate (Metal)**

This technical note describes the minimum standard of work required in order to receive payment.

#### **Requirements**

- A standard new 12ft galvanised seven bar pattern field gate, hot-dip galvanised steel.
- Top and bottom rails should be at least 41mm. Diameter tubes and middle rails at least 32mm. Hanging and slamming posts should be either galvanised steel 88mm diameter tubes or treated softwood 200mm square.

### **P599 - Standard Gate (Hardwood)**

This technical note describes the minimum standard of work required in order to receive payments for 'Standard Gate (Hardwood)'. Any variation must be approved by the Welsh Government prior to starting the work.

You must adhere to the following:

- Install timber field gates that are at least 2.4m wide, but no more than 4.2m wide. Any openings greater than 4.2m must have two leaves.
- Use timber field gates constructed from hardwood only, which complies with the dimensions set out in the diagram below.
- Use timber field gates that conform to the specifications set out in the diagram below as well as those of British Standard 3470, as amended.
- Hang gates on timber gate posts at least 2.1m long. Hanging posts must be at least 200mm x 200mm in cross section. Shutting posts must be at least 175mm x 175mm in cross section.
- Set gateposts correctly into the ground, using concrete if necessary and fit with appropriate hangings and latches.

Do not:

- Use hanging or shutting posts as straining posts for fencing. A short length of split timber should be used to form a horizontal strut between the gate post and adjacent straining post.
- Use second hand material for constructing gates unless approved in advance by the Welsh Government.

### **P600 - Standard Gate (Softwood)**

This technical note describes the minimum standard of work required in order to receive payments for 'Standard Gate (Softwood)'. Any variation must be approved by the Welsh Government prior to starting the work.

You must adhere to the following:

- Install timber field gates that are at least 2.4m wide, but no more than 4.2m wide. Any openings greater than 4.2m must have two leaves.
- Use timber field gates constructed from softwood or pressure treated softwood, which complies with the dimensions set out in the diagram below.
- Use timber field gates that conform to the specifications set out in the diagram below as well as those of British Standard 3470, as amended.
- Hang gates on timber gate posts at least 2.1m long. Hanging posts must be at least 200mm x 200mm in cross section. Shutting posts must be at least 175mm x 175mm in cross section.
- Set gateposts correctly into the ground, using concrete if necessary and fit with appropriate hangings and latches.

Do not:

- Use hanging posts or shutting posts as straining posts for fencing. A short length of split timber should be used to form a horizontal strut between the gate post and adjacent straining post.
- Use second hand material for constructing gates unless approved in advance by the Welsh Government.

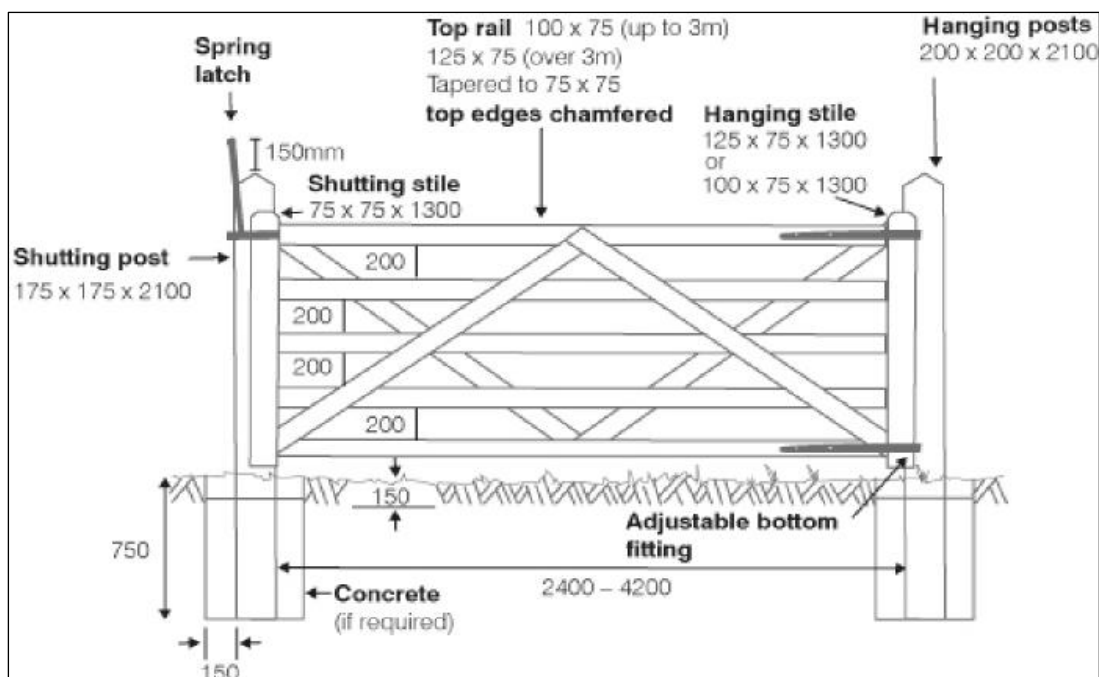

## P516 - Timber Bridle Gate and Posts

These are the minimum standards of work required in order to be eligible to receive payments for 'Timber Bridle Gate and Posts'.

You must adhere to the following:

- Install Timber Bridle Gates and Posts constructed from either pressure treated softwood or hardwood.
- Install gates that are at least 1.5m wide and 1.3m high. Ensure there is sufficient space on one side of the gate for the horse to stand while the gate is being opened.
- Use a ready-made gate or construct a gate. All gate timbers must meet the following dimensions:
  - Uprights should be at least 10cm x 7.5cm in cross section.
  - All rails should be 7.5cm x 2.5cm in cross section except the top rail which should be 10cm x 7.5cm.
- Hang the gate so that it can be opened from both directions.
- Fit latches that allow the gate to be opened without the rider dismounting.

- Ensure that all post timbers must meet the following dimensions; – Hanging posts must be at least 15cm diameter – Shutting posts must be at least 12cm in diameter – Posts must be set into the ground to a sufficient depth to ensure stability.
- Ensure the gate is compliant with BS5709.

Do not:

- Install bridle gates and posts on Public Rights of Way (PRoW) unless approved by the Welsh Government.
- Use concrete to secure posts in the ground, as it can lead to rotting of the posts at ground level.

Requirements and guidance in addition to the specifications above:

- Use an 'extended' or a 'drop over' latch to allow the gate to be opened without the rider dismounting.
- In areas prone to vandalism, the top hook can be reversed to prevent the gate being lifted off.
- Best practice is to set the posts at least 70cm into the ground to ensure stability.

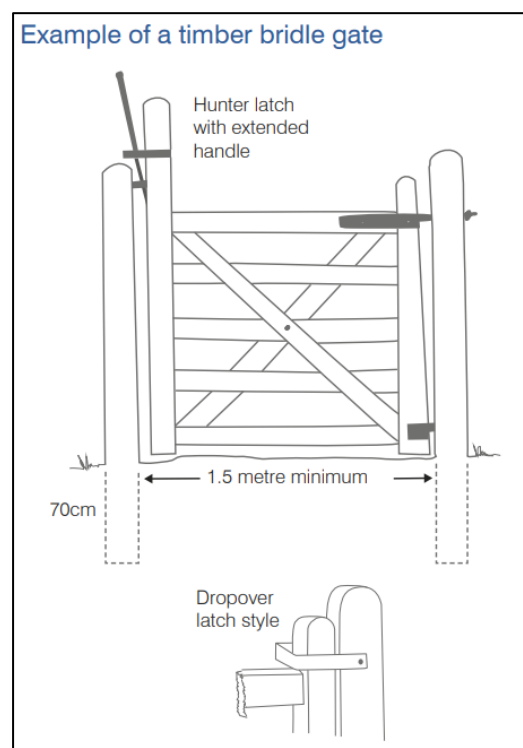



## **P517 - Timber Kissing Gate and Posts**

These are the minimum standards of work required in order to receive payments for 'Timber Kissing Gate and Posts'. Kissing gates are used to allow walkers to cross field boundaries.

You must adhere to the following:

- Install Timber Kissing Gates and Posts constructed from either pressure treated softwood or hardwood.
- Install a kissing gate that is stock-proof with the gate in any position yet allowing free passage for pedestrians.
- Ensure that the kissing gate is an effective barrier against motorcycles and horses.
- Use a ready-made gate or construct a gate. All gates must meet the following dimensions;
- The gate must be 1.2m wide and 1.2m high.
- A 1m cylinder, must be able to pass through. Note that the 'throat' dimension (the narrowest space to pass through when the gate is opened) must be at least 1m.
- Ensure that post and rails meet the following dimensions;
  - Uprights should be at least 10cm x 7.5cm in cross section.
  - Rails should be 7.5cm x 2.5cm in cross section except the top rail which should be 10cm x 7.5cm.
  - Hanging posts must be at least 15cm diameter.
  - Shutting posts must be at least 12cm in diameter.
  - Posts must be set into the ground to a sufficient depth to ensure stability.
- Hang the gate so that the gate hooks are 'offset' by 3cm. This will cause the gate to close against one of the side posts when released.
- Ensure the gate is compliant with BS5709. The least restrictive furniture must be used as possible e.g. a gate is less restrictive than a stile.

Do not:

- Use concrete to secure posts in the ground, as it can lead to rotting of the posts at ground level.

- Use any barbed wire on the kissing gate.

Requirements and guidance in addition to the specifications above:

- For added protection against stock, a self-closing latch can be fitted.
- In areas prone to vandalism, the top hook can be reversed to prevent the gate being lifted off.
- Best practice is to set the posts at least 70cm into the ground to ensure stability

