



Llywodraeth Cymru
Welsh Government

Small Grants – Environment

Capital Works Technical Guidance Booklet Water 2024

Small Grants - Environment is a programme of capital works available to farming businesses across Wales to carry out projects to help improve water quality and reduce the risk of flooding.

Capital Works items will be identified as 'Main' and 'Supportive' Work(s), which, together, form a 'Project'.

The Project will be:

- The Main Capital Work, which will address the theme objectives
- The Supportive Capital Work(s), which will allow the Main Capital Work to be undertaken, e.g. New Hedge Planting (option 900), is the Main Capital Work, while Post and Wire Fencing (option 594), to protect the new hedge from damage, would be a Mandatory Supportive Capital Work, and Hardwood Timber Field Gates (option 599) would be an Optional Supportive Capital Work.

The Water Theme offers Capital Works that have been chosen for their broad and general environmental benefits and their ability to deliver the Welsh Government's ambitions to improve water quality and reduce flood risk.

Contents

Main Capital Works.....	5
E611 Trees and Shrubs (Transplants).....	5
E900 New Hedge Planting.....	8
E901 Hedge Coppicing and Gapping Up	9
E902 Hedge Laying.....	11
E907 Cross Drains.....	12
E908 Kerbing.....	14
E909 Sleeping Policemen	15
E910 Rainwater Goods (Guttering).....	15
E911 Rainwater Goods – Downpipe	16
E912 In-Ditch Wetland.....	17
E913 Soft Engineering of River Banks	19
E914 Pond Restoration	25
E930 Maintenance of Gateways with Hardcore	27
Supportive Capital Works	28
E514 Ladder Stile.....	28
E516 Timber Bridle Gate and Posts	28
E517 Timber Kissing Gate and Posts	30
E519 Wooden Stiles	32
E533 Badger Gate	32
E563 Piped Water Supply.....	33
E573 Water Gate.....	34
E574 Water Troughs	36
E593 Post and Rail Fencing	37
E594 Post and Wire Fencing	38
E931 Post and Wire Fencing with Stock Netting.....	39
E932 Supplement for Rabbit Fence Netting	41
E599 Timber Field Gates (Hardwood).....	42
E600 Timber Field Gates (Softwood)	43
E608 Tree Shelter (60cm With Stake)	44
E647 Spiral Rabbit Guards.....	45
E905 Bramble/Scrub Control – Hand Knapsack Spraying	Error! Bookmark not defined.
E933 Bracken Control (Mechanical Two Cuts/Year)	Error! Bookmark not defined.
E921 Bracken Control (Tractor Mounted Sprayer)	Error! Bookmark not defined.

A Small Grants - Environment Project will be made up of one Main Capital Work underwritten with one or multiple Supporting Capital Works. Please note, Supporting Capital Works are either mandatory, optional or unavailable, depending on which Main Capital Work item is being supported within a Project.

See table below:

Supportive Capital Works

		Code	E514	E516	E517	E519	E533	E563	E573	E574	E593	E594	E931	E932	E599	E600	E608	E647	E905	E933
Main Capital Works	Code	Title	Ladder	Timber	Timber	Wooden	Badger	Piped	Water	Water	* Post	* Post and	* Post and	Supplement for Rabbit Fence Netting	Timber	Timber	# Tree	# Spiral	Bramble/	Bracken
			Stile	Bridle Gate and Posts	Kissing Gate and Posts	Stiles – Rebated	Gate	Water Supply	Gate	Trough	and Rail Fencing	Wire Fencing	Wire Fencing with Stock Netting		Field Gates – Hardwood	Field Gates – Softwood	Shelter [60cm with stake]	Rabbit Guards	Scrub Control – Hand Knapsack Spraying	Control – Mechanical Clearance
	E611	Trees & Shrubs – Transplants	2	2	2	2	2	2	2	2	1	1	1	2	2	2	1	1	2	2
	E900	New Hedge Planting	2	2	2	2	2	2	2	2	0	1	1	2	2	2	2	2	2	2
	E901	Hedge Coppicing and Gapping-up	2	2	2	2	2	2	2	2	0	1	1	2	2	2	2	2	2	0
	E902	Hedge Laying	2	2	2	2	2	2	2	2	0	1	1	2	2	2	0	2	2	0
	E907	Cross Drains	0	0	0	0	0	0	0	0	0	0	0	0	0	0	0	0	0	0
	E908	Kerbing	0	0	0	0	0	0	0	0	0	0	0	0	0	0	0	0	0	0
	E909	Sleeping Policemen	0	0	0	0	0	0	0	0	0	0	0	0	0	0	0	0	0	0
	E910	Rainwater Goods – Guttering	0	0	0	0	0	0	0	0	0	0	0	0	0	0	0	0	0	0
	E911	Rainwater Goods – Downpipe	0	0	0	0	0	0	0	0	0	0	0	0	0	0	0	0	0	0
	E912	In-ditch Wetland	0	0	0	0	0	0	0	0	0	0	0	0	0	0	0	0	0	0
	E913	Soft Engineering of River Banks	0	0	0	0	0	0	0	0	0	0	0	0	0	0	0	0	0	0
E914	Pond restoration	0	0	0	0	2	2	0	2	1	1	1	0	2	2	0	0	0	0	
E930	Maintenance of Gateways (Hardcore)	0	0	0	0	0	0	0	0	0	0	0	0	0	0	0	0	0	0	

• Select **one** mandatory capital work from the three fencing choices

Select **one** mandatory capital work from the two individual tree protection choices

0 Not applicable 1 Mandatory 2 Optional

Main Capital Works

E611 Trees and Shrubs (Transplants)

This technical note describes the minimum standard of work required in order to receive payments for 'Trees and Shrubs (Transplants)'. Any variation must be approved by the Welsh Government prior to starting the work.

Planting small areas of woodland can provide benefits for wildlife and landscape. Growing trees removes carbon dioxide from the atmosphere (which has a positive impact on climate change) and absorbs a lot of water, reducing the amount of water running off farmland into rivers.

You must adhere to the following:

- Plant sturdy plants, which are at least 50cm in height.
- Plant only native species, as shown on the table below.
- Trees and shrubs need to be UK grown and ideally from [Plant Healthy](#) stock for biosecurity reasons

Do not:

- Plant ash trees as part of any planting mix due to ash dieback disease (*Hymenoscyphus fraxineus*).
- Allow damage from machinery or browsing animals (including wild animals).

Requirements and guidance in addition to the specifications above:

- You can establish trees individually or in groups of trees.
- If you are planting trees in groups, they must be established at a planting density equivalent to 400 to 2500 trees per hectare. The width of the area used to plant a group of trees can be **up to a maximum width of 10m wide** in any field parcel. The 10m maximum width limit will be taken from the mapped fence line to the mapped field boundary, which may already include an existing field boundary, such as a hedge, so you may have to include this when establishing the 10m width. You must protect the trees from browsing using spiral rabbit guards **or** tubes and the area of tree planting must also be fenced to exclude livestock.
- Ensure you have the appropriate Flood Risk Activity Permit if you are planting or fencing near a main river, flood plain or flood defence structure. Also, ensure you have the appropriate Ordinary Watercourse Consent if you are carrying out works near an ordinary watercourse. What may be considered a ditch may be an ordinary watercourse, so consent may be required. As such, **the permit/consent, or confirmation that a permit/consent is not needed, should be retained and made available on request.** See Terms and Conditions for more details.
- If undertaking any spraying as part of this activity, ensure you have obtained any consents that may be necessary.
- Where Small Grants - Environment activities include the installation of access furniture, such as stiles or gates on a Public Right of Way, it is your responsibility to ensure you obtain approval under Section 147 of the Highways Act, 1980, from the appropriate Highway Authority.
- Transplants are 1-2 year old plants with a large proportion of root in relation to shoot, which gives them good powers of survival, especially in poor soils and on exposed sites. They will generally outgrow whips in a few years to produce healthier, better-formed trees. A high degree of protection from machinery and animals is needed. Careful maintenance during the first few years is essential. They are considerably cheaper than whips and standards and are usually purchased in bulk.
- Where possible, trees or shrubs should not be planted within 15 metres of ponds. This will ensure, when the trees are grown, they will not shade the surface of the pond. Consideration should also be given when establishing scrub and tree cover to avoid any impact on water supply for ponds or the likelihood of damaging any pond lining.
- The planting season normally runs from 1 October to 30 April. In practice, frost and snow usually divides this period into two planting spells: October to December and during March. At higher altitudes, planting can be extended into early April.
- Autumn planting is preferred for broadleaved trees and shrubs, as roots will grow in warm

spells and lessen the effect of any subsequent spring drought. In exposed sites or areas, where winter gales are likely, spring planting may be preferable.

- Order as far in advance as possible to ensure the correct trees are available. You should request plants are delivered as close as possible to the planting date. It is best to choose an established local nursery because your transport costs should be lower. In addition, the plants will be out of the ground for the minimum length of time.
- Wherever possible, try to obtain plants grown from locally obtained seeds or cuttings (native provenance), since these will do better under local conditions and are more valuable for wildlife than imported stock.
- Try to be on hand when plants arrive so you can ensure they are in good physical condition. Keep the roots covered at all times before planting to prevent damage and drying out. Whilst cold is unlikely to be harmful, hot sun and any form of drying such as wind, can very quickly cause damage or kill the plants.
- If immediate planting is not possible, dig a trench before delivery and store plants in this with the roots covered so they are kept moist and cool. Protect the plants from animals, especially small mammals.
- There are four main methods of planting using a spade, which are illustrated in this note. More specialised tools are available for use on large-scale plantings.
- Use individual tree guards and stakes where lengths of fencing would be uneconomic or unsightly, such as single or widely spaced trees in parklands, or where damage from machinery is possible.
- Annual maintenance is essential to ensure both survival and healthy growth. Plants should be watered, both regularly and liberally, during prolonged dry spells. It is advisable to apply water slowly so it has time to soak into the ground adjacent to the tree. A mulch may serve to reduce the frequency with which watering is needed.
- Plants should be kept clear of competing weeds and grasses (weeding will also reduce mouse and vole damage). Control can be achieved with a thick mulch of bark chippings or by using a 500-gauge black polythene sheet and pegging down securely. Alternatively, carefully cut back grass and other vegetation in the area above the tree roots.
- Weeding is advisable twice in the first year after planting and once a year thereafter, until the tree is clear of surrounding vegetation. Cut weeds by hand or use herbicides to control grasses, docks, thistles and ragwort. If using a strimmer, take care to protect the tree stem from damage. Any chemicals used must have a label recommendation for use on the target species and for the intended method of application. All manufacturers label recommendations regarding method of application must be strictly adhered to.

- Any plants that have been loosened or partly lifted by winds and winter frosts should be trodden back in carefully. Regularly inspect fencing, tree guards, stakes and tree ties (loosen tight ties as these will constrict tree growth) and prevent trees growing through or chafing against tree guards..

Suggested Native Trees and Shrubs Suitable for Planting			
Alder	Cherry (Wild & Bird)	Guelder Rose	Rowan (Mountain Ash)
Aspen	Crab Apple	Hawthorn	Scots Pine
Beech	Dog Rose	Hazel	Spindle
Birch (Silver & Downy)	Elder	Holly	Willow (Crack, Goat & Grey)
Blackthorn	Field Maple	Lime (Small & large leaved)	White Poplar
Black Poplar		Oak (Sessile & Pendunculate)	Yew

For an extensive list of trees native to Wales, see Forest Research's [Using Local Stock for Planting Native Trees and Shrubs](#) (zones 303 and 304 apply).

Example of the four main methods of planting using a spade

1. Pit Planting

Use for large plants or those with bulky root systems

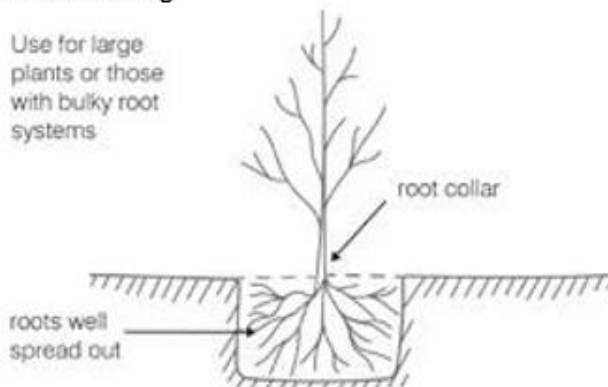

2. Turf Planting

Use on wet sites with poor soil

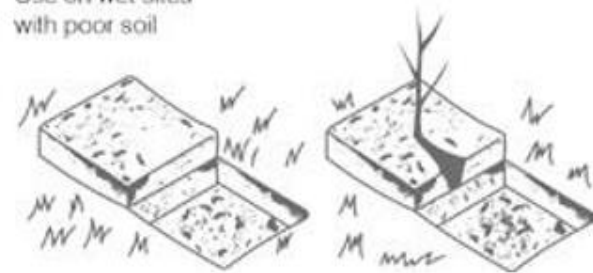

3. Notch or Slit Planting

Use for smaller plants with compact root systems

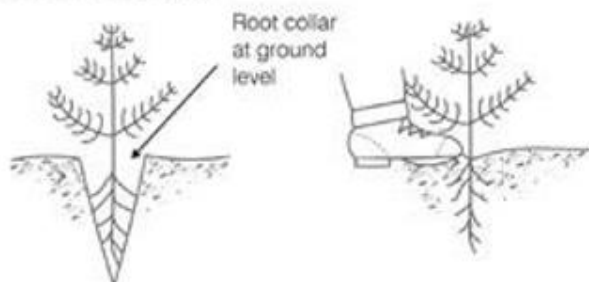

4. Ridge or Mount Planting

Use on wet sites where turf is difficult to cut

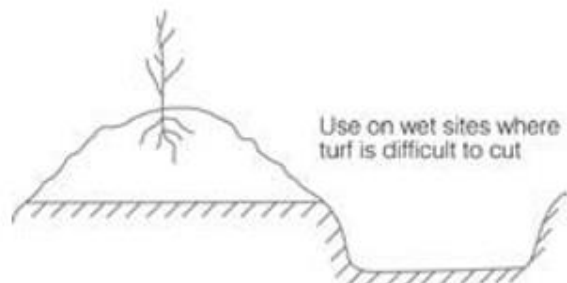

E900 New Hedge Planting

This technical note describes the minimum standard of work required in order to receive payments for 'New Hedge Planting'. Any variation must be approved by the Welsh Government prior to starting the work.

You must adhere to the following:

- Plant native trees and shrubs in a mix of at least three hedging species, with no one component of the mix comprising more than 75% of the total.
- Plant hedge plants that are at least 45-60cm high, which should have a strong leader shoot.
- Plant new hedgerows at a density of 7 plants per metre in a staggered double row, with 20cm between each row.
- Prevent new plants from being killed by shading out from excessive weed growth.
- Protect newly planted hedges from livestock.
- Replace any dead plants.
- Ensure there is at least 1m between new planting and protective fencing.
- **Ensure that the hedge is able to grow to a 3m width. There must be a gap of at least 3m between double fences.** Where a new hedge is planted beside a road, a 1.5m gap from the centre of the hedge to the fence is permissible. The fence must be located on the field side of the hedge.
- Obtain your neighbour's written consent to place a fence on their land if you are planting a new hedge on their boundary.

Do not:

- Plant any ash trees as part of any planting mix due to ash dieback disease (*Hymenoscyphus fraxineus*).
- Use trees and shrubs as strainers or fencing posts, or use them to support fencing wire, staples or netting.
- Cause damage to any existing historic hedge banks during ground preparation, planting or fencing.

Requirements and guidance in addition to the specifications above:

- Ensure that you have the appropriate Flood Risk Activity Permit if you are planting or fencing near a main river, flood plain or flood defence structure. Alternatively, ensure you have the appropriate Ordinary Water Course Consent if you are carrying out works near an ordinary watercourse. What may be considered a ditch may be an ordinary watercourse, so consent may be required. As such, **the permit/ consent (or confirmation that a permit/ consent is not needed) should be retained and made available on request.** See Terms and Conditions for more details.
- If undertaking any spraying as part of this activity ensure you have obtained any consents that may be necessary.
- Where Small Grants - Environment activities include the installation of access furniture such as stiles or gates on a Public Right of Way, it is your responsibility to ensure you obtain approval under Section 147 of the Highways Act, 1980, from the appropriate Highway Authority.
- Ensure the best chances of survival, by planting new hedgerow plants in the winter months from November to March. Keep root balls damp during planting, and water liberally in dry spells until established.
- Select plants with well-developed root systems. Plants which are 3 – 4 years old are recommended
- Prepare the ground for planting by either rotovating, ploughing or digging over during the previous summer. Avoid damaging historic banks during ground preparation by digging manually.
- You may incorporate some well-rotted manure if planting hedge plants on poor soils.
- Plant locally common native species where possible. Plants should be derived from locally collected seed or cuttings if possible as these are likely to survive better and support more species of native wildlife.

- Control weeds by using a mulch of wood chippings or by securely pegging down a 500-gauge black polythene sheet, 1-2m wide at the base of the transplants. Chemical control of grasses, thistles, docks and ragwort may be undertaken.
- Any chemical used must have a label recommendation for use on the listed species and for the intended method of application. All manufacturers label recommendations regarding application of the herbicide must be strictly adhered to.
- Encourage new growth by trimming the transplant back.
- Establish at least 1 – 2 hedgerow trees per 100m. Either plant new saplings (at least 1m tall), or identify existing plants that can develop into trees. It is sensible to tag the tree to avoid accidental damage when hedge trimming. Choose native tree species that grow well in local hedges, as they will contribute to an attractive landscape and can increase the wildlife value of the hedge.
- Spiral guards can be used to protect the hedge from rabbits, although in certain areas rabbit fencing may be a more effective deterrent.

E901 Hedge Coppicing and Gapping Up

This technical note describes the minimum standard of work required in order to receive payments for 'Hedge Coppicing and Gapping-up'. Any variation must be approved by the Welsh Government prior to starting the work.

Please note, hedge trimming with a flail cutter does not meet the technical specification necessary to fulfil the requirement of coppicing the hedge at the level set out below. Hedge Coppicing and Gapping-up projects where a hedge has only been trimmed back, will be rejected.

Coppicing

Hedge coppicing must only be carried out on traditional hedgerows. It should not be carried out on lines of trees, such as riparian woodlands. Coppicing is generally undertaken when a hedge stem is too wide (more than 10cm in width) to lay properly. In some circumstances, the stems may be so wide that you may need to obtain a Felling Licence from Natural Resources Wales. It is your responsibility to check whether or not this is the case.

You must adhere to the following:

- **Copice the hedge to within 7.5cm or less of ground level to allow re-shooting.**
- Retain all large, mature trees where undertaking hedgerow renovation work, particularly those with features such as holes, splits, cracks or dense ivy cover; as these provide roosting sites for bats.
- Plant native trees and shrubs in a mix of at least three hedging species, with no one component of the mix comprising more than 75% of the total.
- Plant hedge plants that are at least 45cm – 60cm high and have a strong leader shoot.
- **Plant new hedgerows at a density of 7 plants per metre in a staggered double row, with 20cm between each row.**
- Prevent new plants from being killed by shading out from excessive weed growth.
- Protect newly planted hedges from livestock.
- Replace any dead plants
- Ensure all redundant fencing or wire is removed.
- Ensure there is at least 1m between new planting and protective fencing.
- **Ensure the hedge is able to grow to a 3m width. There must be a gap of at least 3m between double fences.** Where a hedge is coppiced beside a road, a 1.5m gap from the centre of the hedge to the fence is permissible. **The fence must be located on the field side of the hedge.**
- **Obtain your neighbour's written consent to place a fence on their land if you are planting a new hedge on their boundary.**

Do not:

- Plant ash trees as part of any planting mix due to ash dieback disease (*Hymenoscyphus*

fraxineus), in any planting mix, either for woodlands or when establishing or restoring hedgerows.

- Cause damage to any existing hedge banks during ground preparation, planting or fencing.
- Use trees and shrubs as strainers or fencing posts, or use them to support fencing wire, staples or netting.

Requirements and guidance in addition to the specifications above:

- Depending on the volume of timber felled you may need to obtain a felling licence from Natural Resources Wales.
- Ensure that you have the appropriate Flood Risk Activity Permit if you are planting or fencing near a main river, flood plain or flood defence structure. Alternatively, ensure you have the appropriate Ordinary Water Course Consent if you are carrying out works near an ordinary watercourse. What may be considered a ditch may be an ordinary watercourse, so consent may be required. As such, **the permit/consent (or confirmation that a permit/consent is not needed) should be retained and made available on request.** See Terms and Conditions for more details.
- If undertaking any spraying as part of this activity ensure you have obtained any consents that may be necessary.
- Where Small Grants - Environment activities include the installation of access furniture such as stiles or gates on a Public Right of Way, it is your responsibility to ensure you obtain approval under Section 147 of the Highways Act, 1980, from the appropriate Highway Authority.
- Carry out hedge restoration work between dates permitted by Cross Compliance rules.
- Restricting the hedge restoration dates further to between November and March will be even more beneficial to wildlife such as dormice.
- Ensure the best chances of survival, by planting new hedgerow plants in the winter months from November to March. Keep root balls damp during planting, and water liberally in dry spells until established.
- An additional 1 metre at the base between hedge and fence (on top of the minimum 3 metre width) will create additional wildlife habitat.
- Increasing the species mix beyond the minimum requirement of a 3 species mix will provide a greater selection of food sources for wildlife.
- Select plants with well-developed root systems. Plants which are 3 – 4 years old are recommended.
- Holly and blackthorn are both suitable species to use. Prepare the ground for planting by either rotovating or digging over during the previous summer. Avoid damaging historic banks during ground preparation by digging manually.
- You may incorporate some well-rotted manure if planting hedge plants on poor soils.
- Plant locally common native species where possible. Plants should be derived from locally collected seeds or cuttings if possible as these are likely to survive better and support more species of native wildlife.
- No one component of the mix should comprise more than 75% of the total.
- In previously un-coppiced hedges gaps should be thoroughly cleared of vegetation and hedges cut back to allow healthy growth on both sides.
- Control weeds by using a mulch of wood chippings or by securely pegging down a 500-gauge black polythene sheet, 1m – 2m wide at the base of the transplants. Chemical control of grasses, thistles, docks and ragwort may be undertaken. Any chemical used must have a label recommendation for use on the listed species and for the intended method of application. All manufacturers label recommendations regarding application of the herbicide must be strictly adhered to.
- Encourage new growth by trimming the transplant back.
- Establish at least 1 – 2 hedgerow trees per 100m. Either plant new saplings (at least 1m tall), or identify existing plants that can develop into trees. It is sensible to tag the tree to avoid accidental damage when hedge trimming. Choose native tree species that grow well in local hedges, as they will contribute to an attractive landscape and can increase the wildlife value of the hedge.

- Spiral guards can be used to protect the hedge from rabbits, although in certain areas rabbit fencing may be a more effective deterrent.
- Retain all large mature trees where undertaking hedgerow renovation work, as these can provide roosting sites for bats.
- Where work is required to a tree that has been identified as a bat roost (either because bats are known to be present or where positive signs of bat use have been found), a Habitats Regulations licence from Natural Resources Wales must be obtained.

E902 Hedge Laying

This technical note describes the minimum standard of work required in order to receive payments for 'Hedge Laying'. Any variation must be approved by the Welsh Government prior to starting the work.

You must adhere to the following:

- Ensure that all redundant fencing or wire is removed.
- Lay the hedge by partially cutting through suitable stems at ground level, at an angle of approximately 30°.
- Lay the cut stems as close to ground level as possible, and secure in place with stakes.
- Retain all large, mature trees where undertaking hedgerow renovation work, particularly those with features such as holes, splits, cracks or dense ivy cover as these provide roosting sites for bats.
- Ensure there is at least 1m between new planting and protective fencing.
- **Ensure that the hedge is able to grow to a 3m width. There must be a gap of at least 3m between double fences.** Where a new hedge is planted beside a road, a 1.5m gap from the centre of the hedge to the fence is permissible. **The fence must be located on the field side of the hedge.**
- You must ensure the entire width of the hedge is laid. If part of the width of a hedge falls outside your boundary, you should not include this hedge in your Small Grants – Environment Eol, unless you obtain the written consent from your neighbour to do so.
- Obtain your neighbour's written consent to place a fence on their land if you are planting a new hedge on their boundary.

Do not:

- Use wire or baler twine to secure either the stakes or cut stems.
- Plant any ash trees as part of any planting mix due to ash dieback disease (*Hymenoscyphus fraxineus*), in any planting mix, either for woodlands or when establishing or restoring hedgerows.
- Cause damage to any existing hedge banks during ground preparation, planting or fencing.
- Use trees and shrubs as strainers or fencing posts, or use them to support fencing wire, staples or netting.

Requirements and guidance in addition to the specifications above:

- Depending on the volume of timber felled you may need to obtain a felling licence from Natural Resources Wales.
- Ensure that you have the appropriate Flood Risk Activity Permit if you are planting or fencing near a main river, flood plain or flood defence structure. Alternatively, ensure you have the appropriate Ordinary Water Course Consent if you are carrying out works near an ordinary water course. What may be considered a ditch may be an ordinary watercourse, so consent may be required. As such, **the permit/consent (or confirmation that a permit/consent is not needed) should be retained and made available on request.** See Terms and Conditions for more details.
- If undertaking any spraying as part of this activity ensure you have obtained any consents that may be necessary.
- Where Small Grants - Environment activities include the installation of access furniture such as stiles or gates on a Public Right of Way, it is your responsibility to ensure you obtain approval under Section 147 of the Highways Act, 1980, from the appropriate Highway Authority.

- Carry out hedge restoration work between dates permitted by Cross Compliance rules.
- Restricting the hedge restoration dates further to between November and March will be even more beneficial to wildlife such as dormice.
- Stems for laying should be about 5cm – 10cm thick at the base, and 2.5m – 3.5m in height. Beyond this stage coppicing should be considered as a more suitable alternative.
- An additional 1 metre at the base between hedge and fence (on top of the minimum 3 metre width) will create additional wildlife habitat.
- If planting any gaps, using the widest selection of species available will provide a greater selection of food sources for wildlife.
- Aim to lay hedges in the winter months between November and March.
- Whenever possible follow local traditional methods and customs.
- In the interest of biodiversity, remove only as much elder as is necessary and cut back any bramble, briar or other climbing growth where this impedes laying operations.
- Hedge laying should aim to be upslope and in the same direction wherever possible.
- Maintain existing ash trees where possible.
- Retain all large mature trees where undertaking hedgerow renovation work, as these can provide roosting sites for bats.
- Where work is required to a tree that has been identified as a bat roost (either because bats are known to be present or where positive signs of bat use have been found), a Habitats Regulations licence from Natural Resources Wales must be obtained.

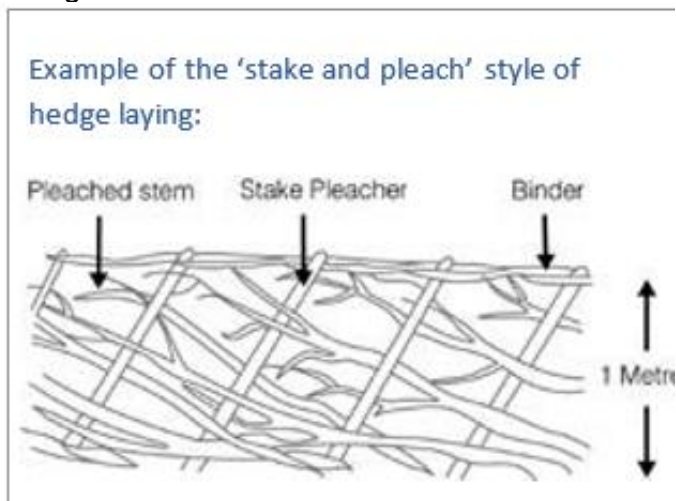

E907 Cross Drains

This technical note describes the minimum standard of work required in order to receive payments for 'Cross Drains'. Any variation must be approved by the Welsh Government prior to starting the work.

The purpose of a cross drain is to help separate clean and dirty water on and around farm yards and tracks. Many streams and rivers in Wales are affected by pollution from agricultural runoff, impacting on biodiversity, fisheries and drinking water quality. Preventing clean water from diluting dirty water at farm yard level means that clean water can be captured for later use, and dirty water remains at more manageable quantities to be properly captured and dealt with appropriately.

Cross drains can be used to intercept clean water from clean tracks and yards upslope of the dirty track/yard areas. This clean water can be diverted into an existing ditch, swale, or sediment trap.

Alternatively, cross drains can be used to intercept foul water downslope of yards/ tracks. This foul water must be diverted into an appropriate slurry store. The open channel of the cross drain is easy to clear of accumulated silt and debris. Foul water must not be diverted into watercourses, drains or onto land.

If you are installing cross drains in farmyards to intercept clean water, you should consider whether you also need to apply for Option 910 Rainwater Goods – Guttering and Option 911 Rainwater Goods – Downpipes.

You can apply for multiple cross drains to span the whole width of wider tracks/yard areas or to install multiple tiers of cross drains across tracks carrying large volumes of water horizontally.

You must adhere to the following:

- Install purposely constructed cross drains, which can be cleared of debris and which can support slow moving heavy machinery.
- Ensure that all cross drains consist of new materials.
- Concrete work should be carried out in accordance with the relevant British Standards BS 8000 and BS 8500, as amended.
- Ensure that clean water from the cross drain is directed to a stable drainage outlet such as a ditch, swale or sediment trap.
- Ensure that foul water is discharged into an appropriate slurry store.

Requirements and guidance in addition to the specifications above:

- Ensure that you have the appropriate Flood Risk Activity Permit if you are planting or fencing near a main river, flood plain or flood defence structure. Alternatively, ensure you have the appropriate Ordinary Water Course Consent if you are carrying out works near an ordinary water course. What may be considered a ditch may be an ordinary watercourse, so consent may be required. As such, **the permit/consent (or confirmation that a permit/consent is not needed) should be retained and made available on request.** See Terms and Conditions for more details.

How to install a cross drain – best practice

The work will include the purchase and installation of a polychannel drainage system with grating. The channel once installed should be able to support the weight of slow moving heavy machinery, and can easily be cleared of accumulated silt and debris.

- Excavate a trench across the width of the track or along part of the farm yard, allowing sufficient depth and width for the concrete bed and surround.
- Make sure the outlet of the trench runs into a suitable ditch or swale.
- Slope the bed of the trench towards the outlet, following the depth of the proposed channel.
- Ensure that any arrows on the side of the channel point towards the outlet i.e. in the direction of flow.
- Set levels and lay out the channels alongside the trench, always starting at the outlet point.
- Pour bedding – begin at the outlet position, a good quality concrete bedding should be poured into the trench.
- Working away from the outlet, lower the channels into position following the manufactures instructions.
- Check alignment of channel.
- The grating should be loosely laid and wrapped in plastic, spanning the channel joints to ensure a clean final installation.
- The concrete surround can now be poured into the trench, taking care not to disturb the line of the run. This should finish 3mm above the channel and grating top surface.
- Once the concrete has set, lift out gratings and remove the protective plastic.
- To support heavy slow moving machinery a minimum concrete bed and surround of 200mm is required, unless specified otherwise with polychannel installation instructions.



E908 Kerbing

This technical note describes the minimum standard of work required in order to receive payments for 'Kerbing'. Any variation must be approved by the Welsh Government prior to starting the work.

What is the purpose of this activity?

The purpose of installing kerbs on and around farm yards and alongside tracks is to help separate clean and dirty water. Many streams and rivers in Wales are affected by pollution from agricultural run-off, impacting on biodiversity, fisheries and drinking water quality.

Kerbs can be used to divert dirty water away from on-yard gullies or other areas where it may contribute to run-off and potential pollution.

The dirty water can then be channelled into an appropriate store or slurry store.

Alternatively, kerbs can be used to divert clean water away from dirty track/yard areas.

Preventing clean water from diluting dirty water at farm yard level means that clean water can be captured for later use, and dirty water remains at more manageable quantities to be appropriately captured in slurry stores and dealt with properly.

If you are installing kerbs in farmyards to intercept clean water, you should consider whether you also need to apply for Option 910 Rainwater Goods – Guttering and Option 911 Rainwater Goods – Downpipes.

You must adhere to the following:

- Install kerbing with new kerbstones measuring 900mm x 255mm x 125mm (half battered)
- Concrete work should be carried out in accordance with the relevant British Standards BS 8000 and BS 8500, as amended.
- Ensure that clean water from the kerbing is directed to a stable drainage outlet such as a ditch, swale or sediment trap.
- Ensure that foul water is discharged into an appropriate slurry store.

Requirements and guidance in addition to the specifications above:

- Ensure that you have the appropriate Flood Risk Activity Permit if you are planting or fencing near a main river, flood plain or flood defence structure. Alternatively, ensure you have the appropriate Ordinary Water Course Consent if you are carrying out works near an ordinary watercourse. What may be considered a ditch may be an ordinary watercourse, so consent may be required. As such, **the permit/consent or confirmation a permit/consent is not needed, should be retained and made available on request.** See Terms and Conditions for more details.

Kerbing – best practice

- Kerbing is likely to be more stable if a trench is excavated in the existing track to a minimum depth of 300mm.
- Fill with concrete and key in pre-cast concrete kerb stones protruding from the surface.
- Tamper the concrete on the outer side to the top edge of the kerb stone.
- Leave concrete on the inner side (the side that will divert the water) flat, below the top of the kerbstone.

E909 Sleeping Policemen

This technical note describes the minimum standard of work required in order to receive payments for 'Sleeping Policemen'. Any variation must be approved by the Welsh Government prior to starting the work.

What is the purpose of this activity?

The purpose of a sleeping policeman is to help separate clean and dirty water on and around farmyards and tracks. Many streams and rivers in Wales are affected by pollution from agricultural run-off, impacting on biodiversity, fisheries and drinking water quality.

Preventing clean water from diluting dirty water at farm yard level means that clean water can be captured for later use, and dirty water remains at more manageable quantities to be appropriately captured in slurry stores and dealt with properly.

Sleeping policemen can be used to intercept clean water from clean tracks and yards upslope of the dirty track/yard areas.

Alternatively, they can be used to intercept foul water downslope of yards/tracks. This foul water must be diverted into an appropriate store or slurry store.

Installing sleeping policemen across farm tracks can also intercept and divert surface run-off, reducing flow rates at down slope locations and therefore helping to prevent erosion on farm track surfaces. By taking action to slow run-off you can reduce water damage to tracks, minimise soil erosion and reduce the risk of water pollution.

If you are installing sleeping policemen in farmyards to intercept clean water, you should consider whether you also need to apply for Option 910 Rainwater Goods – Guttering and Option 911 Rainwater Goods – Downpipes.

You must adhere to the following:

- Create sleeping policemen to a height of at least 150 mm above track level, which can support slow moving heavy machinery.
- Concrete work should be carried out in accordance with the relevant British Standards BS 8000 and BS 8500, as amended.
- Ensure that clean water from the sleeping policemen is directed to a stable drainage outlet such as a ditch, swale or sediment trap.
- Ensure that foul water is discharged into an appropriate slurry store.

Requirements and guidance in addition to the specifications above:

- Ensure that you have the appropriate Flood Risk Activity Permit if you are planting or fencing near a main river, flood plain or flood defence structure. Alternatively, ensure you have the appropriate Ordinary Water Course Consent if you are carrying out works near an ordinary water course. What may be considered a ditch may be an ordinary watercourse, so consent may be required. As such, **the permit/consent (or confirmation that a permit/consent is not needed) should be retained and made available on request.** See Terms and Conditions for more details.
- Sleeping policemen are likely to be more stable if a trench is excavated in the existing track to a minimum depth of 100mm, and then key concrete into the trench and up to a height of at least 150mm.

E910 Rainwater Goods (Guttering)

This technical note describes the minimum standard of work required in order to receive payments for 'Rainwater Goods – Guttering'. Any variation must be approved by the Welsh Government prior to starting the work.

What is the purpose of this activity?

The purpose of new rainwater goods is to help separate clean rain water from dirty water on and around farmyards. Many streams and rivers in Wales are affected by pollution from agricultural run-off, impacting on biodiversity, fisheries and drinking water quality. Preventing rainwater from diluting dirty water at farmyard level means that dirty water remains at more manageable

quantities to be appropriately captured in slurry stores and dealt with properly.

Guttering can be used to intercept and capture rainwater from farm building roofs. This clean water can be diverted into an existing clean water drain or discharged to an existing ditch, swale, or sediment trap. Alternatively it may be captured for later on-farm use.

Payments are available for the provision and installation of new rainwater goods (guttering and downpipes), where existing ineffective or non-existent rainwater goods discharge clean water onto fouled yard areas.

This option is for existing buildings, traditional or modern, within the farmyard that currently do not have rainwater goods or which have existing rainwater goods that are beyond their serviceable life and need replacement. Non-agricultural buildings and houses are not eligible.

Rainwater goods on proposed new buildings are not eligible for a grant as they should already have rainwater goods built into the design.

Listed buildings are not eligible for this option.

You must adhere to the following:

- Use guttering, typically 150mm half round PVC guttering, and appropriate brackets. All goods must satisfy all relevant British Standards, as amended, such as BS EN 607, BS EN12200 and BS EN 1462.
- Installation work should satisfy all relevant British Standards, as amended, such as BS 5502 and BS EN1917.
- Ensure that all rainwater goods consist of new materials.

Do not:

- Install plastic rainwater goods on Listed Buildings.

E911 Rainwater Goods – Downpipe

This technical note describes the minimum standard of work required in order to receive payments for 'Rainwater Goods – Downpipe'. Any variation must be approved by the Welsh Government prior to starting the work.

What is the purpose of this activity?

The purpose of new rainwater goods is to help separate clean rain water from dirty water on and around farm yards. Many streams and rivers in Wales are affected by pollution from agricultural run-off, impacting on biodiversity, fisheries and drinking water quality. Preventing rainwater from diluting dirty water at farm yard level means that dirty water remains at more manageable quantities to be appropriately captured in slurry stores and dealt with properly.

Downpipes can be used to intercept and capture rain water from farm building roofs.

This clean water can be diverted into an existing clean water drain or discharged to an existing ditch, swale, or sediment trap. Alternatively, it may be captured for later on-farm use.

Payments are available for the provision and installation of downpipes where existing ineffective or non-existent rainwater goods discharge clean water onto fouled yard areas.

This option is for existing buildings, traditional or modern, within the farmyard that currently do not have rainwater goods or which have existing rainwater goods that are beyond their serviceable life and need replacement. Non-agricultural buildings and houses are not eligible.

Rainwater goods on proposed new buildings are not eligible for a grant as they should already have rainwater goods built into the design.

Listed buildings are not eligible for this option.

You must adhere to the following:

- Use 110mm downpipe and brackets that satisfy all relevant British Standards, as amended, such as BS EN 607, BS EN12200 and BS EN 1462.

- Installation work should satisfy all relevant British Standards, as amended, such as BS 5502 and BS EN1917.
- Ensure that all rainwater goods consist of new materials.
- Any underground drainage works should comply with all relevant British Standards, as amended, such as BS 8000, BS EN 752 and BS EN 1610.

Do not:

- Install plastic rainwater goods on Listed Buildings.

Requirements and guidance in addition to the specifications above:

- Where rainwater goods are at risk of being damaged by livestock, suitable protection should be installed.

E912 In-Ditch Wetland

This technical note describes the minimum standard of work required in order to receive payments for 'In-ditch Wetland'. Any variation must be approved by the Welsh Government prior to starting the work.

In-ditch wetlands are ditches that have been widened to create a broader shallower wetland area. They are designed so vegetation slows the flow of water, to increase sediment deposition from field surface runoff, field drains, and ditches.

The purpose of an in-ditch wetland is to:

- Improve water quality: In-ditch wetlands trap sediment carried in runoff from fields and farmland, which could otherwise pollute rivers and lakes downstream.
- Reduce flooding: In-ditch wetlands slow the flow of water by providing valuable space where runoff can disperse, providing storage for floodwater which helps reduce flooding downstream.
- Create a wildlife habitat: In-ditch wetlands provide additional positive benefits to the nature conservation (nesting habitat for wetland birds in particular reed buntings, reed, sedge and Cetti's warbler) and landscape value at the farm scale.

You must adhere to the following:

- Choose a location within existing man made field ditches with a low gradient, where the land on either side is within your control. These are otherwise known as Stage 1 ditches which do not have continuous flow year round. The diagram below shows a typical ditch network.
- Widen the chosen area to a minimum of 10m in length and to a maximum of 3m wide and flatten the bed.
- Create a soil bund with a pipe at the lower end of the ditch to act as an outflow. The bund should be made wider than the ditch. The top should be level and at least 50cm above the intended water line. The bund should have slightly sloping sides.
- Insert one or two pipes within the bund to act as an outflow. The pipes should be between 8 – 10” in diameter, and located 30cm (12”) below the top of the bund.
- Extend the pipe beyond the bund base on the downstream side of the bund to prevent the outflow eroding the bund.
- Plant up the bed with native sedge, rush or reed species, or with willow or Alder. For reed, rush and sedge species, plant at a density of 3 plants/m².

Do not:

- Locate in-ditch wetlands on natural watercourses.
- Damage other habitats such as reed beds to create in-ditch wetlands.

- Create this option between 1 March and 31 August.

Requirements and guidance in addition to the specifications above:

- Ensure that you have the appropriate Flood Risk Activity Permit if you are planting or fencing near a main river, flood plain or flood defence structure. Alternatively, ensure you have the appropriate Ordinary Water Course Consent if you are carrying out works near an ordinary watercourse. What may be considered a ditch may be an ordinary watercourse, so consent may be required. As such, **the permit/consent (or confirmation that a permit/consent is not needed) should be retained and made available on request.** See Terms and Conditions for more details.
- This option must not be used on natural watercourses, due to legislation requiring fish passage to be ensured at all times.
- Carry out this activity when ground conditions are as dry as possible between September and February. Temporarily bund the water flow into this area if needed, which will improve access for excavating and planting.
- Spread the excavated material thinly over the top of the banks so as to prevent weeds such as common nettle, creeping thistle etc., from dominating. Ensure the silt cannot run straight back into the in-ditch wetland.
- When constructing the bund, remove topsoil and scarify the subsoil to improve the seal between the dam and the ground surface. Build the bund slowly in layers 15cm thick and compact each layer in turn.
- Take care during completion of the activity to ensure no sediment laden water is allowed to enter the receiving watercourse.
- Do not plant with willow or alder if sedimentation is likely to be high.
- Plant up the bed with plant species already found in the local area. Do not collect protected plant species, or collect from a Site of Special Scientific Interest (SSSI). This is in line with Cross Compliance Regulations.
- For willow species plant at a density of 1 plant per m² and for alder species at 2m² spacing.
- Coppice willow and alder species every 3-5 years. Reed, rush and sedges plants should be cut every other year to prevent them from dominating the wetland. Cut in early spring before bird nesting to provide maximum roosting cover in the winter.
- This activity should be sited and managed to ensure no risk of flooding results.

In-ditch wetland (aerial view)

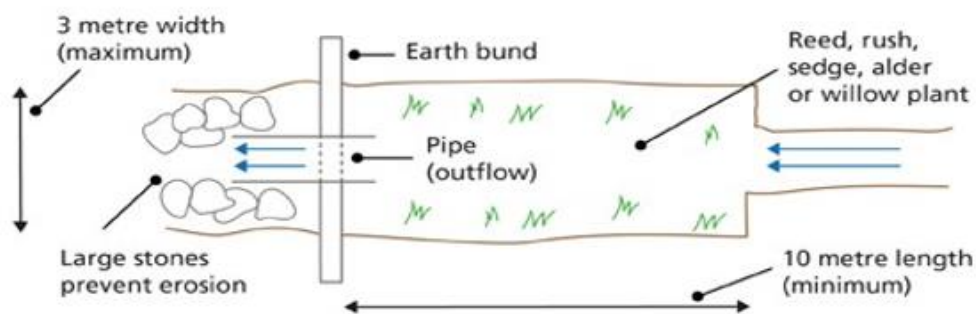

In-ditch wetland (x-sectional view of earth bund)

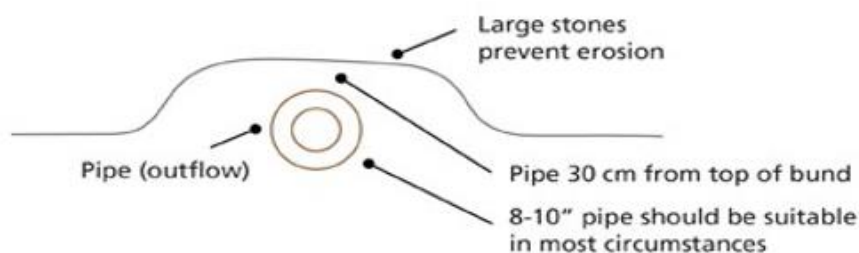

Watercourse stages

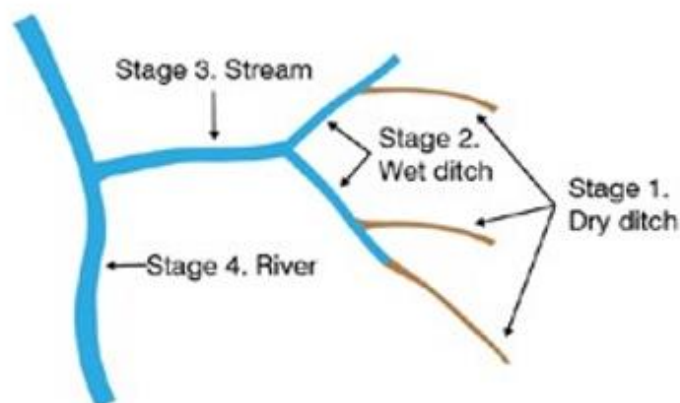

E913 Soft Engineering of River Banks

This technical note describes the minimum standard of work required in order to receive payments for 'Soft Engineering of River Banks'. Any variation must be approved by the Welsh Government prior to starting the work.

What is the purpose of this activity?

Riverbanks and the riparian zones immediately behind the bank top provide valuable wildlife habitat that can support a wide range of plant and animal species. They supply shelter, food and shade and protect the river from surface runoff. Riverside vegetation and the fibrous roots of that vegetation help to maintain the stability of the bank, and prevent downstream flooding and further erosion by reducing the river's energy.

Naturally occurring erosion of riverbanks is an important river process that reduces the energy of river flows, redistributes sediment and provides nesting locations for birds such as sand martins and kingfishers. However, human activity can increase erosion. Livestock, for example, can destabilise banks through poaching and removing vegetation, while river engineering such as gravel removal, re-profiling and hard engineering works can increase the energy of the river and increase erosion.

Soft engineering (or bio-engineering) measures utilise natural processes to reduce future

negative erosion whilst allowing the area to re-vegetate and stabilise. Compared with traditional 'hard' defences (e.g. rock, concrete, gabions) woody materials create more diverse habitats for plants, invertebrates and fish. Soft engineering measures are more resilient in the long term as the materials used are flexible, so they absorb and dissipate the erosive forces rather than simply reflect energy as per hard defences. Furthermore, areas of soft engineering can be coppiced in the future to supply a ready and freely available source of materials for use on neighbouring sites.

River engineering is difficult and it is worth obtaining expert advice on the most appropriate techniques. Your local rivers trust, the River Restoration Centre (www.therrc.co.uk/) or Natural Resources Wales may all be able to recommend the most appropriate approach, or supply further guidance.

You must adhere to the following:

- Install the correct quantity of river bank soft engineering on damaged or eroding watercourses, using sufficient stakes and withies to ensure a stable and robust structure. Guidelines for choosing and constructing the correct style of soft engineering are laid out below.

Do not:

- Graze the area of soft engineering.
- Use soft engineering as a retaining structure.
- Allow soft engineering to block water flow in small river channels.

Requirements and guidance in addition to the specifications above:

- Ensure that you have the appropriate Flood Risk Activity Permit if you are planting or fencing near a main river, flood plain or flood defence structure. Alternatively, ensure you have the appropriate Ordinary Water Course Consent if you are carrying out works near an ordinary water course. What may be considered a ditch may be an ordinary watercourse, so consent may be required. As such, **the permit/consent (or confirmation that a permit/consent is not needed) should be retained and made available on request.** See Terms and Conditions for more details.
- There are different bank protection techniques using live and dead woody material that may be suitable depending on the site. Select which of these techniques (or combination) is suitable for your site, and follow the guidance below.
 - Willow spiling is a traditional technique used to stabilise eroding banks.

It involves weaving live willow rods (withies) between vertical live willow stakes set into the affected bank at regular intervals to create a living fence like structure, or 'revetment'. The space behind the willow fence to the existing bank is then filled with soil to provide an area for the willow roots to grow.

There are 2 types of spiling – producing a tighter weave for revetments below water level, and a looser weave for revetments above water level.

- Hurdles can be used instead of spiling where the nature of the site makes it dangerous or unsuitable to create spiling in situ.
- Faggoting (brushwood or brashings tied in bundles) can be used by themselves or in conjunction with spiling or hurdles depending on the nature of the site. Faggots (or fascines) are bundles of willow or brushwood, bound together and used for various stabilisation and revetment purposes. Faggots slow the flow of moving water and trap silt and sediment, and the buried branches then help consolidate the sediments against renewed erosion.
- Do not use in locations where other habitat is present that could be harmed by increased willow cover e.g. fens, wet unimproved grassland, wet heath, rhos pasture, bogs, or areas where you know ground nesting birds such as lapwing or curlew nest.

Spiling

1a: A tight weave spiling for revetments below water level.

- Installing revetments below water level may require specialist contractors.

- Use vertical stakes of 65-100mm (2.5-4") diameter for spilings up to 600mm high.
- For spilings up to 900mm (3') high, thicker stakes of 100-130mm (4-5") diameter will be needed.
- Use crack willow (*Salix fragilis*) or white willow (*Salix alba*) to produce the best material for stakes.
 - Knock the stakes in vertically along the line of the revetment, about half a metre apart and so that two-thirds of the finished height of the stake is below soil level, then cut the tops to the finished height.
 - Use withies which have a butt diameter of 10-20mm (0.25-0.75") and be of a length equivalent to five times the stake spacing, to give a close, tight weave.
 - Use osier (*Salix viminalis*), goat willow (*Salix caprea*) or grey willow (*Salix cinerea*) to produce the best material for withies.
 - Weave the withies between the stakes, alternating the direction of the butt ends and tucking both ends in so they don't protrude. At the end of each length of revetment, the spiling should be run into the bank so that the last two to three stakes are completely buried after backfilling.
 - Backfill to the required bank profile with soil once stakes and withies are securely placed.
 - Place faggots (see below) behind the spiling where there is a risk of backfill washing out.
 - Undertake spiling between November and March (when average temperatures are below 2°C).
 - Use freshly cut willow for the vertical stakes and horizontal withies, so that they will sprout and produce a living revetment.
 - Pollarding or coppicing of bank side willow, or pruning of earlier spiling, will produce suitable material of the sizes mentioned above.
 - Where willow is unavailable, alder can be used as an alternative. Willow or alder should be of local origin where possible.
 - Stakes and withies can be stored between November and February for up to three weeks, provided they are kept cool and damp. Outside this season, they are best used within 48 hours of cutting and are always best having been soaked immediately before use.
 - Where there is a risk of vandalism wire down the top withies and secure to the stake with a staple.
 - It is advisable to exclude stock for at least 2 or 3 years until the willow structures have established and the ground has become stabilised.

Example of tight weave spiling below water level

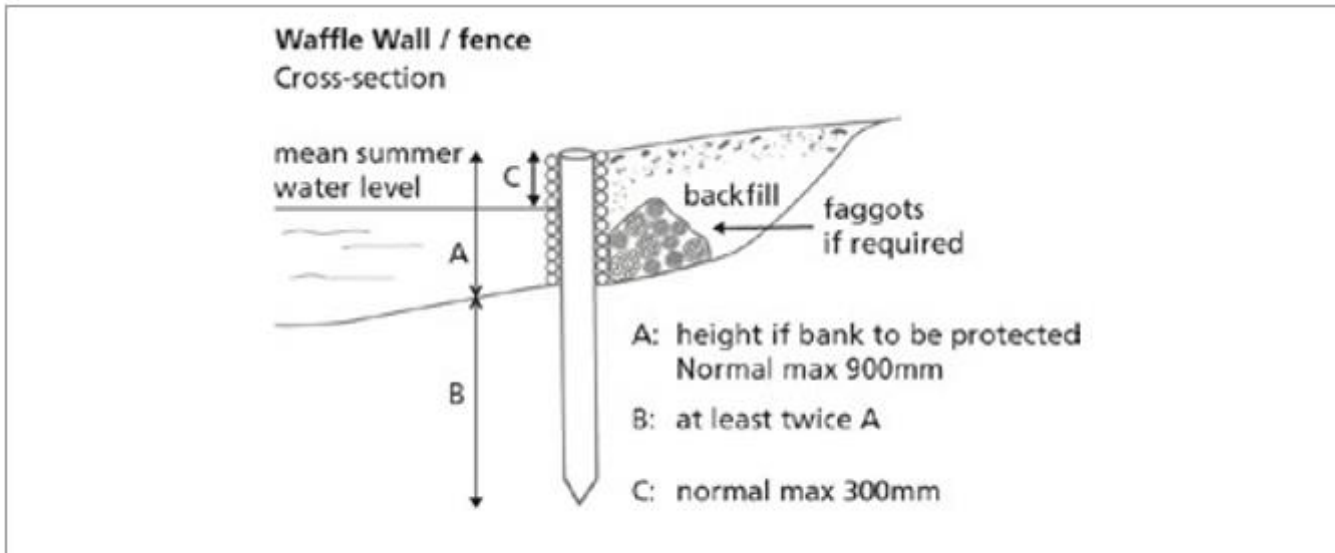

Waffle Wall / fence
Face View

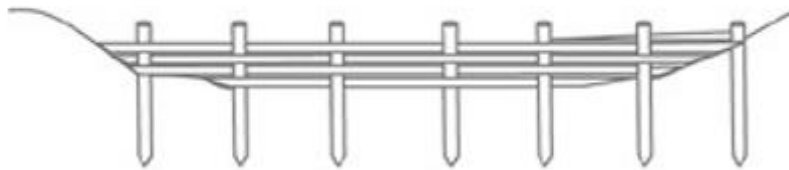

1b: A looser weave spiling for revetments above water level

- Insert the stakes as described for 1a above.
- Start weaving the withies between the second and third stake from one end. Push the end of the withy into the ground, and then weave between the stakes towards the end stake. Push the next withy into the ground and weave it alongside the first. The withies will root at the ends.
- Continue weaving along the stakes, until the withies reach the top of the stakes.
- Ensure the top withies are tightly woven to secure the spiling.
- Where there is a risk of vandalism wire along the top or down through the spiling.
- It is advisable to exclude stock for at least 2 or 3 years until the willow structures have established and the ground has become stabilised.

Example of tight weave spiling below water level

Looser weave Waffle Wall / fence

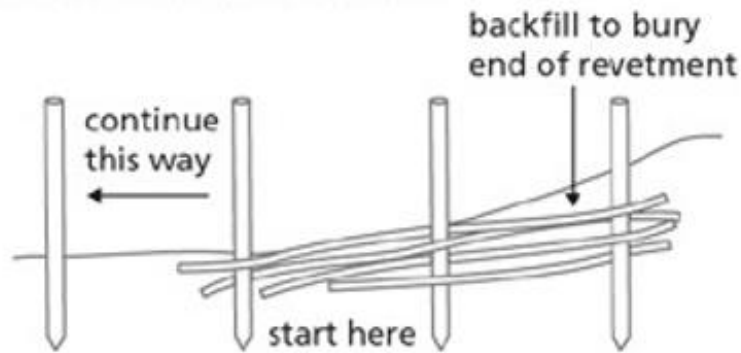

Hurdles

- Construct hurdles from hazel and willow.
- Construct hurdles to a maximum size that can be safely moved into position. Typically, a hurdle is 1.8m (6') long by 1m (3.5') high.
- Construct the hurdle from a series of upright 'zales' which should be at least 90cm tall, and no more than 25cm (10") apart, interwoven with tightly packed series of horizontal rods. A typical construction method is described below.
- Use two 1.5m (5') stakes for each hurdle, knock the stakes into position on the outer side of the revetment and wire the hurdles to the stakes to hold them in place.
- Backfill the hurdle with faggots and/or spoil.
- Construct hurdles off-site if working conditions at the bankside are difficult, however, ensure the hurdles are of a size and weight that you are able to transport. The structure should be strong enough to survive handling and positioning.
- If possible, use split hazel for the uprights or 'zales', as they hold the laterals better than round poles. Willow is also acceptable and is more suitable for the horizontal weaving.
- Push 900mm (3') 'zales' about 300mm (1') into the ground, evenly spaced in a straight line as shown.
- Weave hazel or willow rods between the 'zales', tucking each end back under itself to lock the wands in place. Force the wands down with your foot to give a tight weave. It may be necessary to wire or tie the top wands to discourage vandalism.
- Lift out the sections for transport to the site. Place the hurdles in position, overlapping as shown, below, and drive them in as far as the lower wands.

Waffle fence / hurdles

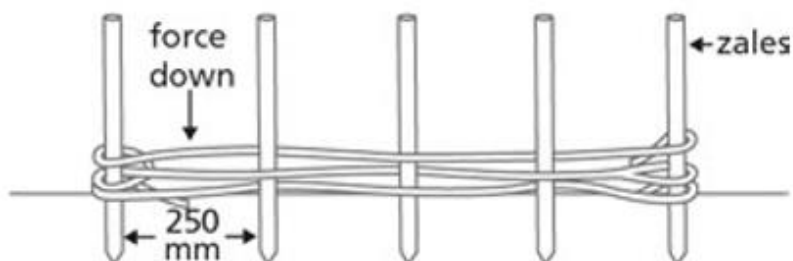

Faggots

- Construct faggots to a maximum size that can be safely moved by two people. Typically, the traditional size is about 2m (7') long and 300mm (1') diameter, bound at three points.
- Bind the faggots with twisted willow, baler twine or wire.
- Secure the positioned faggots by attaching them to stakes knocked well down into the bank.

Secure the faggot to the stake with wire. The faggots should be positioned as shown in the diagrams below, or placed behind hurdles, or spiling revetments. Consider using live willow cut in the winter as this is likely to root and grow. Growing willows are beneficial as their roots help to stabilise bank material and their shoots provide protection against bank scour.

- To stabilise a bank the faggots can be laid in a single or double row, secured by stakes and wire as shown. As necessary, another layer can be added cross-wise.
- Smaller faggots, of about 100mm diameter can be bound together to form 'mattresses', for laying on banks, subject to boat wash or strong flows. A large faggot at the base absorbs some of the wave energy.

Faggots (Willow bundles)

Aerial Plan

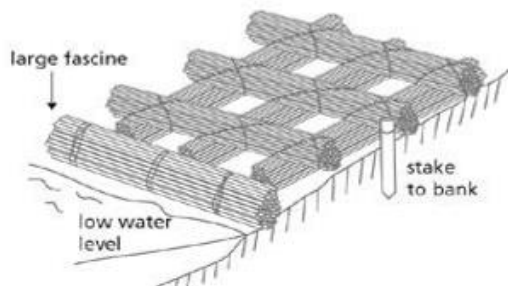
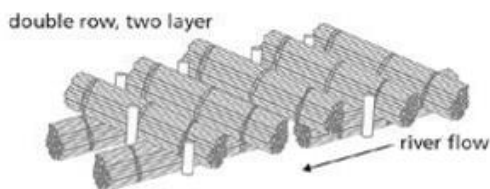
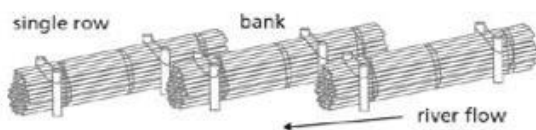
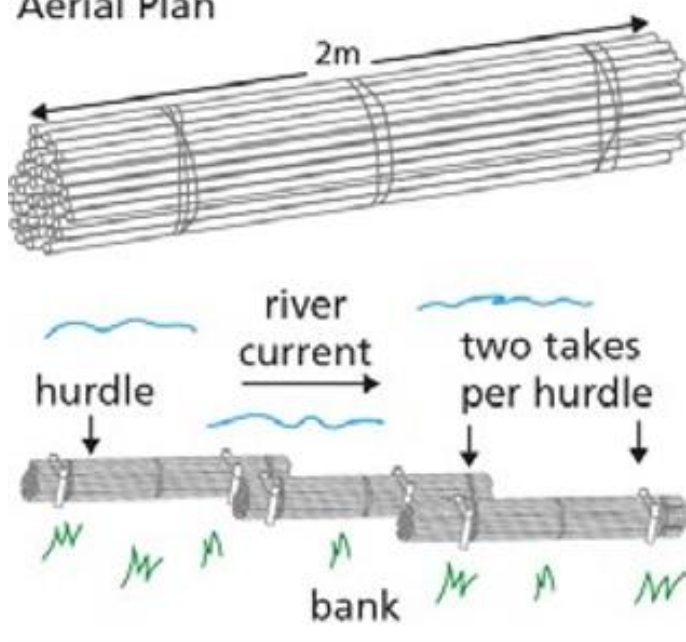

E914 Pond Restoration

This technical note describes the minimum standard of work required in order to receive payments for 'Pond Restoration'. Any variation must be approved by the Welsh Government prior to starting the work.

Ponds and other small water bodies are important for freshwater biodiversity and storing water. Areas with large numbers of ponds can be particularly important because they provide habitats for a wider range of plants and animals.

Ponds are particularly vulnerable to nutrient enrichment, siltation and domination by invasive plants. Causes of this include nutrient-rich runoff from fields and farmyards, high stock densities causing overgrazing and poaching of margins, feeding of waterfowl and stocking with fish. Invasive species may spread naturally or by deliberate or accidental introduction.

There are many different kinds of 'good' pond and you should not try to make all ponds on your farm look the same. A range of different sorts of ponds provide the widest range of habitats and can support some of our most threatened animals and plants.

If you have more than one pond, managing vegetation and silt on a staggered rotation of about 10 years will provide a range of different habitats.

Nevertheless, there are some general rules. Good ponds tend to have:

- Extensive areas of shallow water;
- Not too many fish or water birds;
- Clear water;
- A range of different water plants with no invasive species;
- Lightly grazed margins with no more than about half the pond shaded.

Ponds do not need to contain water all year, and some rare animals and plants need temporary ponds where predators cannot survive. However, water levels must be allowed to vary naturally, but the pond should contain water for at least 6 months per year.

Do not introduce animals or plants to your pond, especially from a garden pond, or a garden centre. Native pond species are good dispersers, and will arrive in healthy ponds by themselves. The following types of pond are not suitable for this Small Grants - Environment pond restoration option:

- A significant inflow or outflow 1m or more wide. This is because watercourses often carry silt and/or pollutants.
- Significant water quality problems that cannot be addressed by the restoration measures of this option. If there is serious pollution, disposal of material can be problematic and restoration is much less likely to be effective.
- Constructed wetlands or other traps for dirty water. These ponds are designed to trap pollution.
- Ponds with large numbers of fish or ducks make poor habitat for wildlife due to heavy predation.
- Ornamental ponds or ponds with non-native invasive species. These ponds make poor habitat for wildlife and restoration activities may encourage spread of invasive animals and plants.

You must adhere to the following:

- Maintain a buffer strip of long vegetation between the pond and any upslope intensively managed land.
- Ensure you have prevented any sources of pollution and nutrients from reaching the pond including any run offs that may contain fertilisers, slurries, manures, silage effluent or other nutrients.
- Remove any scrap, redundant fencing or any other rubbish such as plastic wrap.
- Spread any removed silt on adjacent land in compliance with waste exemption U10 and waste exemption D1.
- Exclude all stock from accessing the pond by ensuring there is at least 1 metre between the fence and water's edge. Stock access can be permitted to 10% of the pond area.

- Create a mixed pattern of trees and shrubs around the pond by coppicing some scrub to allow more light onto the surface of the water and reducing leaf drop into the pond.

Do not:

- Restore ponds between March and August.
- Dredge more than one third of the surface area of a pond at any time.
- Allow dredged silt to run back into the pond. Dredged material must be spread down slope from the pond, but not where it may run into adjacent watercourses.
- Create islands in the pond.
- Allow stock drinking access for more than 10% of the pond.
- Remove any old trees from around the pond as they may contain bird nesting sites, bat roosts and rare mosses and lichens.

Requirements and guidance in addition to the specifications above:

- Ensure that you have the appropriate Flood Risk Activity Permit if you are planting or fencing near a main river, flood plain or flood defence structure. Alternatively, ensure you have the appropriate Ordinary Water Course Consent if you are carrying out works near an ordinary watercourse. What may be considered a ditch may be an ordinary watercourse, so consent may be required. As such, **the permit/consent (or confirmation that a permit/consent is not needed) should be retained and made available on request.** See Terms and Conditions for more details.
- Ensure that you apply for a European Protected Species licence from Natural Resources Wales (NRW) if you have Great Crested Newts in or close to the pond. This should not normally prevent restoration works since these will generally be beneficial to newts, but it is important to include sufficient time for the application process.
- This Small Grants - Environment project includes dredging a maximum of one third of the pond. The remaining two thirds should be dredged in rotation in future years, but this is not included within this Small Grants - Environment project. This ensures that invertebrate populations are not totally removed.
- Do not damage ponds that are considered existing habitat such as reed beds, fens or ponds on unenclosed land. It may be possible to obtain grants for pond restoration on existing habitat but this will require further discussion and/or consultation with Natural Resources Wales to ensure that no damage is being done to a Section 7 Habitat or Species, protected species or feature of a Protected Site.
- To minimise impacts on wildlife, restore ponds between September and January. Aim to do work in dry weather when pond levels are low and machinery will run less risk of poaching the soil.
- Removing silt from the pond is appropriate when:
 - No submerged aquatic plants can be seen, either because the water is very turbid or because the bed is clearly covered by a deep, loose layer of silt or leaf litter.
 - The sediment is completely black and smells of rotten eggs, and large bubbles of gas can be seen bubbling up occasionally.
- If removing from the pond, scrape out loose sediment until a firmer layer such as clay, marl or other firmer sediment is reached. Take care not to break the natural seal of the pond bed.
- Do not create artificial islands as they encourage gulls and waterfowl, resulting in poor water quality.
- If there is a danger of leaching from adjacent intensively managed fields, consider establishing a strip of long vegetation adjacent to the pond which can act as a buffer strip.
- The Million Ponds website also has useful information regarding restoring ponds for other protected species such as Great Crested Newts and Water Vole:
<https://freshwaterhabitats.org.uk/projects/million-ponds/>
- More information on ghost ponds can be found at <http://ghostponds.wordpress.com/>
- More information on waste exemption U10 (<https://www.gov.uk/guidance/waste-exemption-u10-spreading-waste-to-benefit-agricultural-land>)
- More information on waste exemption (<https://www.gov.uk/guidance/waste-exemptions->

[disposing-of-waste](#)) D1 and registering waste exemptions.

Diagram – Cross Section of Pond

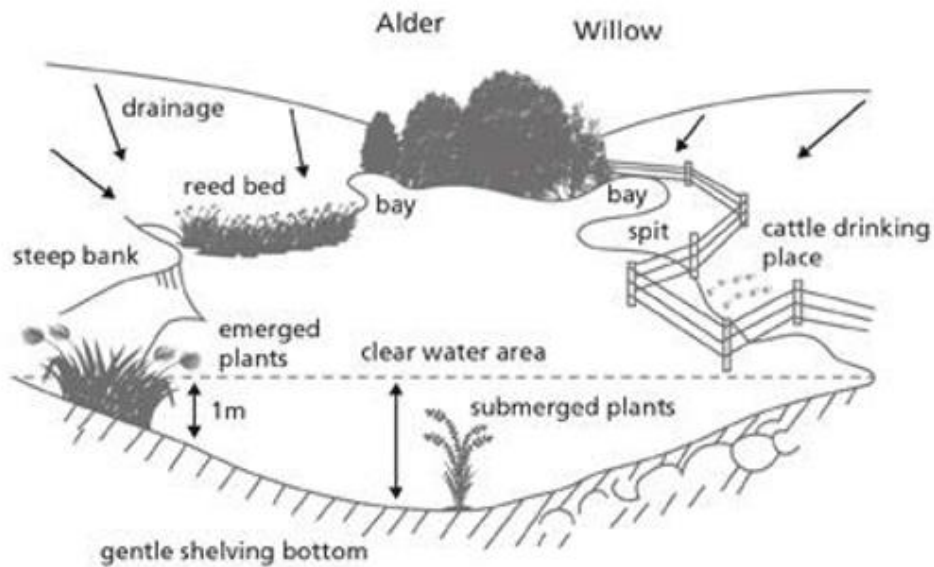

E930 Maintenance of Gateways with Hardcore

This technical note describes the minimum standard of work required in order to receive payments for 'Maintenance of Gateways'. Any variation must be approved by the Welsh Government prior to starting the work.

What is the purpose of this activity?

Gateways and other areas which are frequently used by livestock and farm vehicles can be at increased risk of compaction and erosion. Compaction leads to poor drainage where water collects and pools.

Gateways can also act as exit points for run off from a field. Many streams and rivers in Wales are affected by pollution from agricultural runoff, which impacts on biodiversity, fisheries and drinking water quality. Installing hardcore in gateways will help reduce compaction, erosion and any resulting run off.

You must adhere to the following:

- Lay stone to a minimum depth of 200mm across the gateway and approach to create a flat even hardcore pad.
- Repair any damage or excessive wear such as that caused by harvesting or natural events to area of hardcore immediately.

Do not:

- Use concrete to set the stone in place.
- Use the hardcore pad as a location for feeders, drinking troughs or to store vehicles and machinery.

Requirements and guidance in addition to the specifications above:

- Ensure that you have the appropriate Flood Risk Activity Permit if you are planting or fencing near a main river, flood plain or flood defence structure. Alternatively, ensure you have the appropriate Ordinary Water Course Consent if you are carrying out works near an ordinary water course. What may be considered a ditch may be an ordinary watercourse, so consent may be required. As such, **the permit/ consent (or confirmation that a permit/ consent is not needed) should be retained and made available on request.** See Terms and Conditions for more details.

Supportive Capital Works

E514 Ladder Stile

This technical note describes the minimum standard of work required in order to receive payments for 'Ladder Stile'. Any variation must be approved by the Welsh Government prior to starting the work.

Ladder stiles are used to allow walkers to cross walls and banks.

You must adhere to the following:

- Construct the ladder stile from pressure treated softwood or hardwood.
- Use timber with dimensions no less than those shown in the diagram. The steps can either be rebated into the 'A' frames or supported by extra pieces of timber. Secure the stile on both sides by burying the ends of the 'A' frame to a sufficient depth in the ground and anchoring them with stobs as shown.
- Construct a platform at the top of the stile to cross over wide walls or banks if needed.
- Ensure the gate is compliant with BS5709:2006, as amended. The least restrictive furniture must be used as possible, e.g. a gate is less restrictive than a stile.

Do not:

- Use ladder stiles on a Public Right of Way (PROW) unless approved by the Welsh Government.
- Use concrete to secure timber supports in the ground.
- Reduce the size of wide walls or banks to enable the ladder to span the boundary. Construct a platform at the top of the stile if needed.
- Requirements and guidance in addition to the specifications above:
- Best practice is to bury the ends of the 'A' frame at least 30cm into the ground to anchor the stile.

Example of a step ladder stile

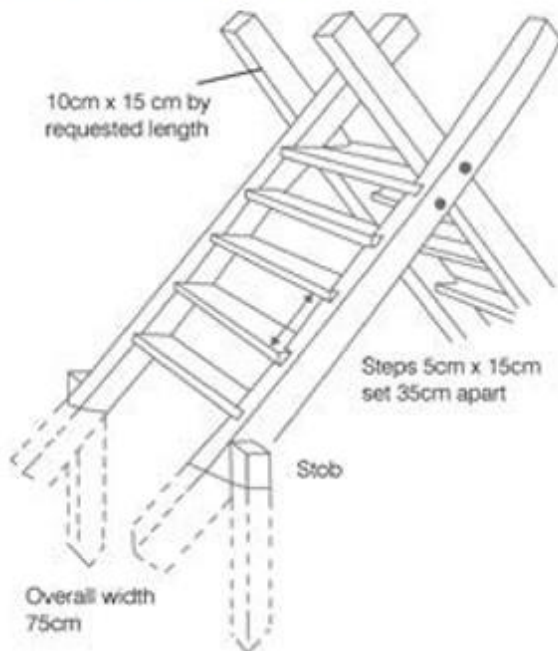

E516 Timber Bridle Gate and Posts

This technical note describes the minimum standard of work required in order to receive payments for 'Timber Bridle Gate and Posts'. Any variation must be approved by the Welsh Government prior to starting the work.

Bridle gates are used to allow access for walkers and horse riders.

You must adhere to the following:

- Install Timber Bridle Gates and Posts constructed from either pressure treated softwood or hardwood.
- Install gates that are at least 1.5m wide and 1.3m high. Ensure there is sufficient space on one side of the gate for the horse to stand while the gate is being opened.
- Use a ready-made gate, or construct a gate. All gate timbers must meet the following dimensions:
 - Uprights should be at least 10cm x 7.5cm in cross section.
 - All rails should be 7.5cm x 2.5cm in cross section except the top rail which should be 10cm x 7.5cm.
- Hang the gate so that it can be opened from both directions.
- Fit latches that allow the gate to be opened without the rider dismounting.
- Ensure that all post timbers must meet the following dimensions;
 - Hanging posts must be be at least 15cm diameter
 - Shutting posts must be at least 12cm in diameter
 - Posts must be set into the ground to a sufficient depth to ensure stability.

Do not:

- Install bridle gates and posts on Public Rights of Way (PRoW) unless approved by the Welsh Government.
- Use concrete to secure posts in the ground, as it can lead to rotting of the posts at ground level.
- Requirements and guidance in addition to the specifications above:
- Use an 'extended' or a 'drop over' latch to allow the gate to be opened without the rider dismounting.
- In areas prone to vandalism, the top hook can be reversed to prevent the gate being lifted off.
- Best practice is to set the posts at least 70cm into the ground to ensure stability.

Example of a timber bridle gate

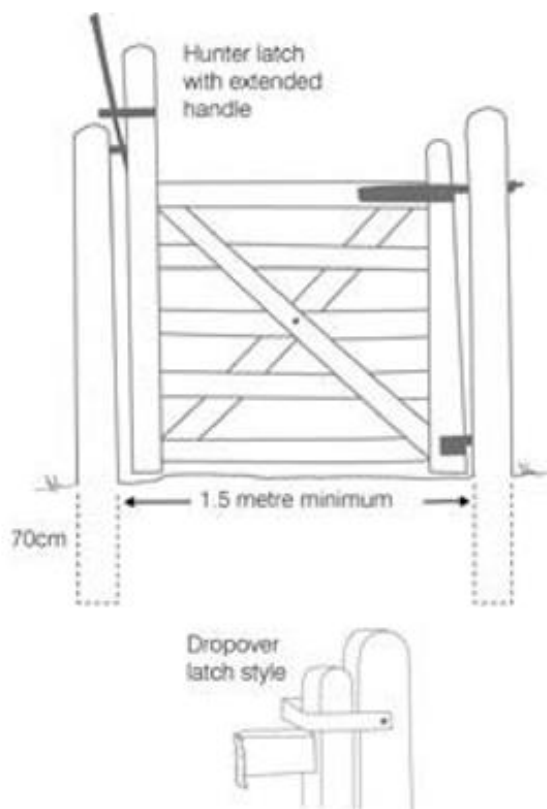

E517 Timber Kissing Gate and Posts

This technical note describes the minimum standard of work required in order to receive payments for 'Timber Kissing Gate and Posts'. Any variation must be approved by the Welsh Government prior to starting the work.

Kissing gates are used to allow walkers to cross field boundaries.

You must adhere to the following:

- Install Timber Kissing Gates and Posts constructed from either pressure treated softwood or hardwood.
- Install a kissing gate that is stock-proof with the gate in any position, yet allowing free passage for pedestrians.
- Ensure that the kissing gate is an effective barrier against motorcycles and horses.
- Use a ready-made gate, or construct a gate. All gates must meet the following dimensions;
 - The gate must be 1.2m wide and 1.2m high.
 - A 1m cylinder, must be able to pass through. Note that the 'throat' dimension (the narrowest space to pass through when the gate is opened) must be at least 1m.
- Ensure that post and rails meet the following dimensions;
 - Uprights should be at least 10cm x 7.5cm in cross section.
 - Rails should be 7.5cm x 2.5cm in cross section except the top rail which should be 10cm x 7.5cm.
 - Hanging posts must be at least 15cm diameter.
 - Shutting posts must be at least 12cm in diameter.
 - Posts must be set into the ground to a sufficient depth to ensure stability.
- Hang the gate so that the gate hooks are 'offset' by 3cm. This will cause the gate to close against one of the side posts when released.
- Ensure the gate is compliant with BS5709:2006, as amended. The least restrictive furniture must be used as possible e.g. a gate is less restrictive than a stile.

Do not:

- Use concrete to secure posts in the ground, as it can lead to rotting of the posts at ground level.
- Use any barbed wire on the kissing gate.

Requirements and guidance in addition to the specifications above:

- For added protection against stock, a self-closing latch can be fitted.
- In areas prone to vandalism, the top hook can be reversed to prevent the gate being lifted off.
- Best practice is to set the posts at least 70cm into the ground to ensure stability.

Example of a timber kissing gate

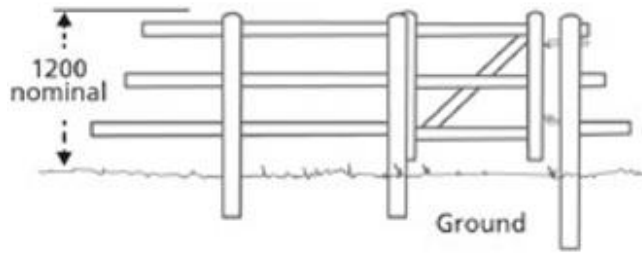

All dimension in mm,
not to scale

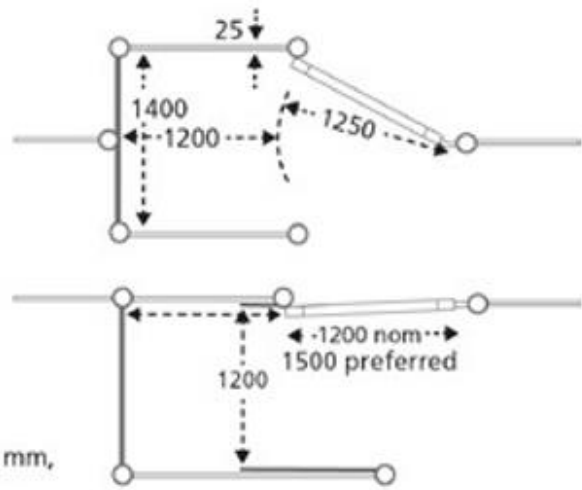

E519 Wooden Stiles

This technical note describes the minimum standard of work required in order to receive payments for 'Wooden Stiles'. Any variation must be approved by the Welsh Government prior to starting the work.

Wooden stiles are used to allow walkers to cross field boundaries.

You must adhere to the following:

- Install wooden stiles constructed from either pressure treated softwood or hardwood.
- Use a ready-made stile kit, or construct a stile. For both narrow and wide stiles, they must meet the following dimensions;
 - Step width should be 200min
 - Hand posts should be 70 to 100mm diameter or across faces
 - Posts should be vertical to 1 in 30
 - Steps should level in all directions to 1 in 30.
- Install a third step on the downhill side on a steep slope if needed. This step must be twice the width of a standard step and the 300mm step height rule applies.
- Ensure the stile is compliant with BS5709:2006, as amended. The least restrictive furniture must be used as possible e.g. a gate is less restrictive than a stile.

Do not:

- Allow the step tread boards to touch the cross-rails of the stile as a see-saw effect may develop, making the stile unsafe to use.
- Use posts as straining posts for fencing.

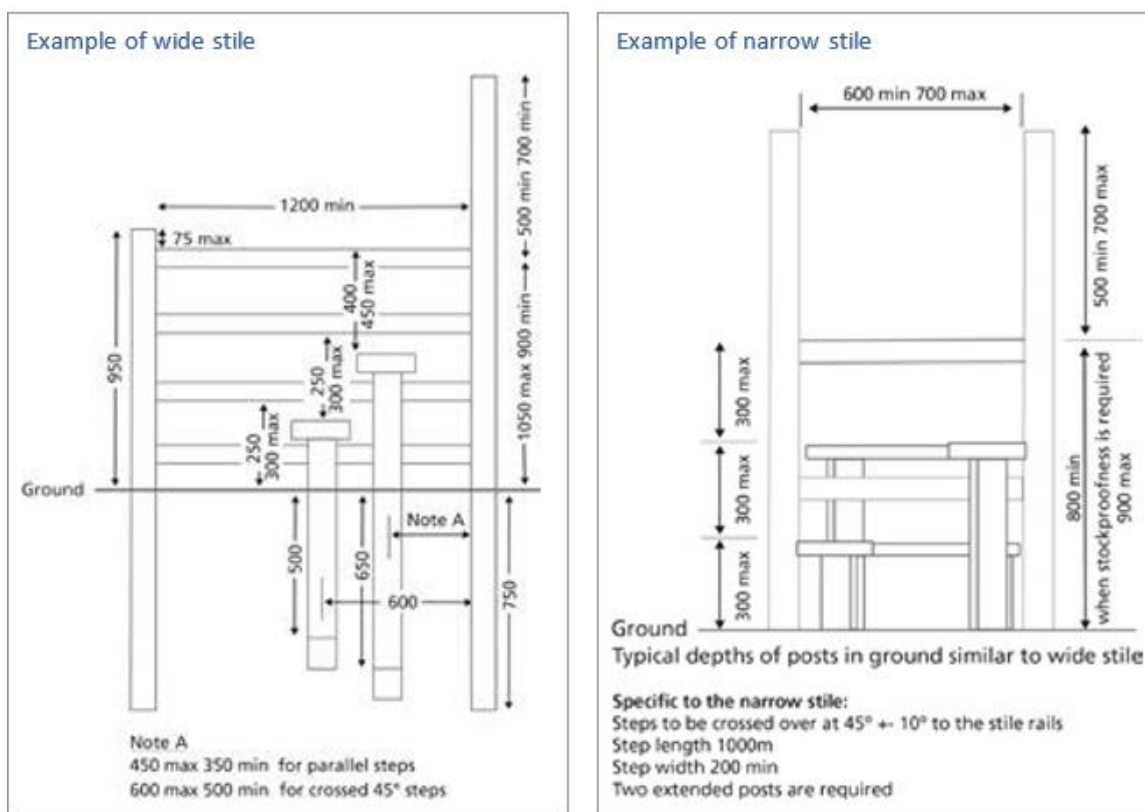

E533 Badger Gate

This technical note describes the minimum standard of work required in order to receive payments for 'Badger Gates'. Any variation must be approved by the Welsh Government prior to starting the work.

Badgers normally follow the same route when moving around their territory. Fencing to manage

an area of habitat should take into account established badger runs. Badger gates can be used to allow badgers to cross stock proof boundaries without damaging the fences.

You must adhere to the following:

- Install a badger gate using the same dimensions as shown in the diagram below.
- Gates must be located directly on existing badger runs in order to encourage the use of the gate by badgers.
- Bury the fence on either side of the gate to a sufficient depth into the ground to prevent badgers burrowing around the gate.
- Position a wooden or stone base under the gate to prevent erosion of the ground.

Requirements and guidance in addition to the specifications above:

- Best practice is to bury the fence to a depth of at least 15cm either side of the gate.
- Treat all timbers with a non-toxic, odourless preservative.

Example of a badger gate

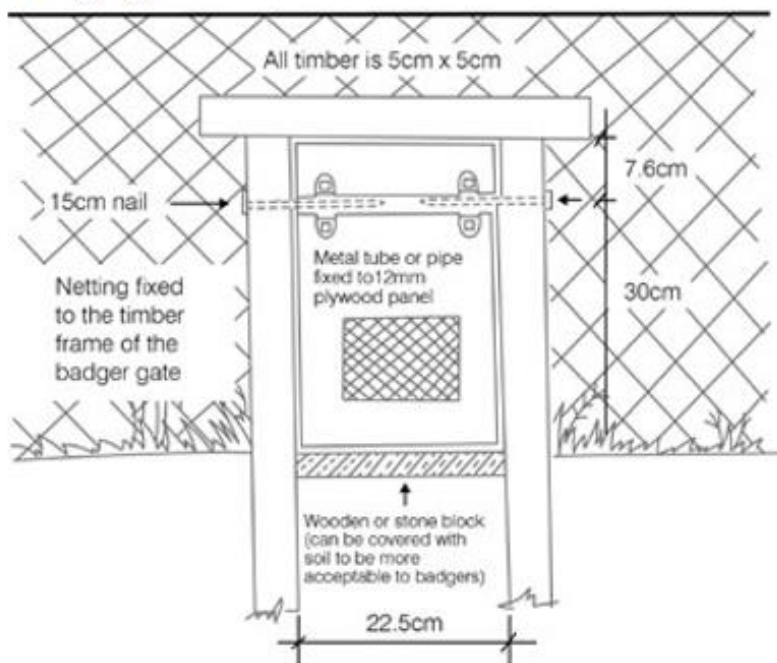

E563 Piped Water Supply

This technical note describes the minimum standard of work required in order to receive payments for 'Piped Water Supply'. Any variation must be approved by the Welsh Government prior to starting the work.

Piping can be used to supply drinking water to water troughs where stock have been prevented from accessing other water sources by Small Grants - Environment activities.

You must adhere to the following:

- Install piping made from medium density blue polyethylene with a minimum external diameter of 2.5 cm.
- Use watertight joints made of brass or plastic.
- Bury pipework to a sufficient depth to prevent damage from surface activities.
- Reinstate disturbed ground to match the surrounding ground once pipework has been completed.
- Protect any pipework above ground from animal or frost damage.

- Ensure any pipes crossing open ditches or tracks are suitably protected. The pipe must be covered by a tubular steel guard or sleeve pipe, laid sufficiently below the ditch to allow space for ditch cleaning. When crossing farm tracks, ensure the pipe is sufficiently protected below the track.
- Control water supply at the point of supply and at each trough by isolating valves/stop cocks. The isolating valves/stop cocks must be protected against frost and damage from stock, and must be easily accessible.
- Where valve/stop cocks are buried, this must be at a minimum of 60cm and access should be available through a covered inspection chamber.
- Ensure that the water is able to supply sufficient cold potable water to continuously refill all the water troughs along its length throughout the year within 10 minutes.
- Ensure all water supply works are compliant with British Standards Codes of Practice BS 6572, as amended.

Do not:

- Damage other services such as water supply, waste, gas, electricity or telephone.

Requirements and guidance in addition to the specifications above:

- Consider combining access to valve positions with field drains to make inspection access easier.
- Consider a range of factors when determining pipe diameter. These include: water pressure, water capacity, variable flow, length of pipe, changes in altitude, volume of water required, number of troughs, number and type of stock using each trough.
- Where joints are buried underground, it is advisable to mark their locations, on fence posts for example, to assist with future maintenance.
- Bury pipework to a minimum depth of 60cm although this may need to be deeper if future deep ploughing or sub-soiling is envisaged.
- Lay pipes by trenching, mole plough or sub-soiler, depending on soil type and machinery available.
- Best practice when laying pipes under a ditch is that it is laid 60cm below the ditch to allow space for ditch cleaning.
- Best practice when laying pipes under farm tracks is to lay the pipe on a 7.5cm bed of sand and then covered by a further 10cm of sand before being overlaid by backfill.

E573 Water Gate

This technical note describes the minimum standard of work required in order to receive payments for 'Water Gate'. Any variation must be approved by the Welsh Government prior to starting the work.

Water gates are required to control stock where fence lines cross rivers and streams. They are especially useful where the water level varies considerably throughout the year.

You must adhere to the following:

- Construct a gate comprising a series of wooden droppers attached to a length of cable or a round wooden rail which is suspended horizontally between straining posts. Each gate has to be constructed to fit the profile of the individual stream.
- Ensure the water gate is separated from the main fence line by short lengths of wooden rail or netting, fixed to straining posts that have been suitably positioned.
- Attach droppers that are at least 5cm square in cross section. Droppers must be constructed from sawn untreated timbers. The droppers must be drilled and threaded onto the cable of fencing wire with 15cm lengths of plastic pipe acting as spacers. As a result, each dropper is

15cm apart.

- Increase the dimensions of the droppers to at least 7cm square, where the stream gully is over 1.5m deep. Hang droppers on a round wooden pole using loops of fencing wire.

Requirements and guidance in addition to the specifications above:

- Suitable crossing points will have a hard river bottom and reasonable access from both banks. The correct choice of crossing points will make both construction and maintenance easier.
- Hanging the gate separately from the main fence allows the gate to be pulled off during heavy floods without damaging the main fence. Minimum damage will be caused to the gate which can then be recovered, repaired and repositioned.
- It is advisable to create larger water gates in several sections which will reduce the risk of the whole gate being lost or damaged during severe floods.
- It is advisable to periodically clear the base of the water gate, as the accumulation of debris at the base of the water gate will put pressure on both wires and stakes and can result in damage.
- Hang water gates at an angle, with the bottom of the gate resting on the streambed on the downstream side. This prevents stock passing underneath when the water level drops.

Examples of water gates

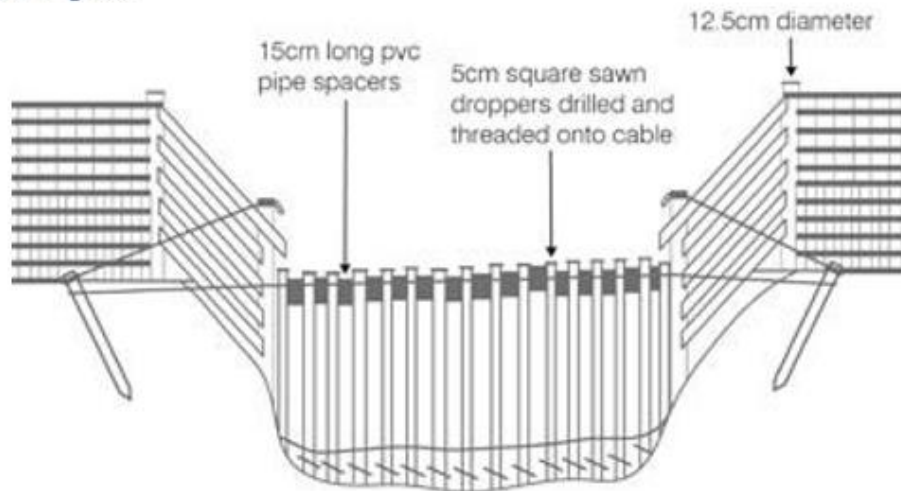

Examples of water gates

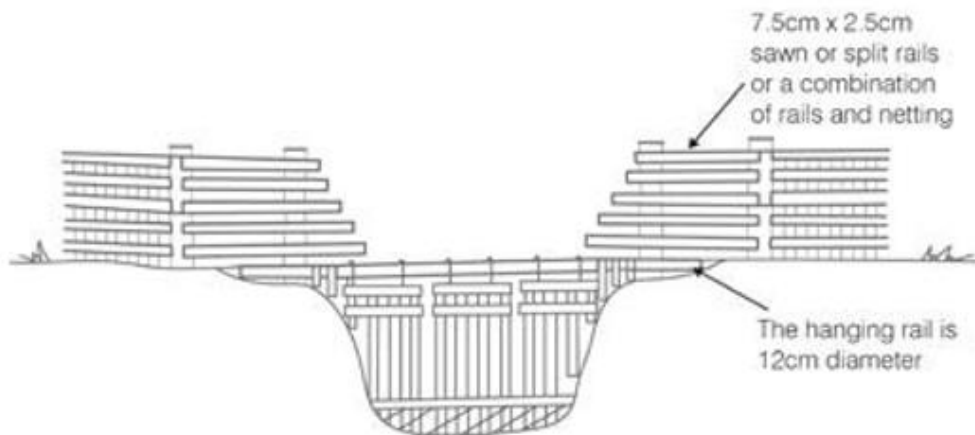

E574 Water Troughs

This technical note describes the minimum standard of work required in order to receive payments for 'Water Troughs'. Any variation must be approved by the Welsh Government prior to starting the work.

Water troughs can be used to supply drinking water to livestock where they have been prevented from accessing other water sources by Small Grants - Environment activities.

You must adhere to the following:

- Use water troughs made of galvanised steel, plastic or concrete.
- Install a trough at least 1.8m length. They must either be connected to a water supply or supplied from a bowser on a regular basis, in order to provide sufficient potable water. The standard payment includes the cost of fittings such as ball cocks etc.
- Use water troughs that have been specifically designed for the purpose.
- Install the trough so that it does not spill or leak water – the payment rate includes an allowance for base supports.
- Ensure that water troughs conform to current British Standard Codes of Practice.

Do not:

- Locate water troughs in gateways or near footpaths.
- Locate water troughs in wet ground due to the risk of poaching.

Requirements and guidance in addition to the specifications above:

- Do not locate water troughs in known areas of botanical or wildlife interest.
- Aim to cause least landscape impact by locating the trough at the edge of fields, and choose a material that has the minimum impact when viewed as part of the surrounding landscape.
- Install troughs of sufficient size to supply the type and number of stock in the field with their water requirements.

Example of a water trough

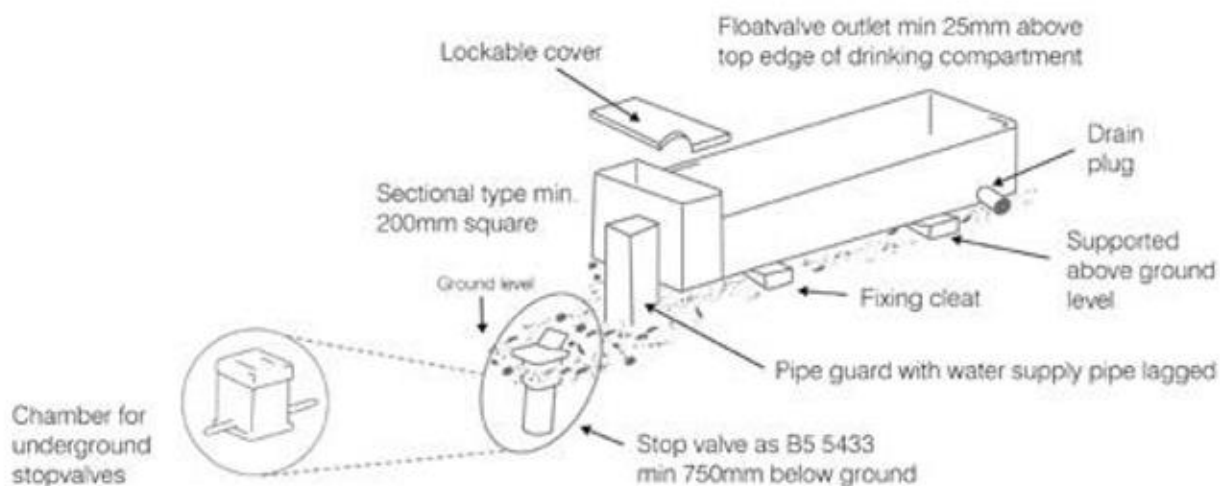

E593 Post and Rail Fencing

This technical note describes the minimum standard of work required in order to receive payments for 'Post and Rail Fencing'.

Any variation must be approved by the Welsh Government prior to starting the work.

Post and rail fencing is generally used where appropriate in the landscape, normally in parkland areas or for stock control along waterside features.

You must adhere to the following:

- Use fencing timber comprising either hardwood or pressure treated softwood.
- Use posts that are at least 1.8m in length, and no less than 12.5cm x 7.5cm cross section.
- Use posts that are square or rectangular.
- Install posts at centres not exceeding 2m (normally 1.8m as the standard length of rails is 3.6m).
- Set posts at a sufficient depth into the ground to ensure stability. The face of the post must be square to the fence line. If the tops of the posts are sawn after setting, the cut surfaces must be treated with a suitable preserving fluid of the same colour as the original timber treatment.
- Attach at least three rails of 3.8cm x 8.7cm sawn timber, skew nailed to the posts. Additional rails may be added where necessary.
- Attach rails on the 'stock' side of the posts, to prevent stock pushing rails off posts.
- Alternate joints between rails on the posts, as shown on the diagram.
- Ensure there is at least 1m from the ground to the top of the uppermost rail.

Do not:

- Use trees and shrubs as strainers or fencing posts, or attach wire, staples or netting to them.
- Use concrete to secure the posts as it promotes rotting of the posts at ground level.

Requirements and guidance in addition to the specifications above:

- Best practice is to set the posts at least 70cm into the ground to ensure stability, and secure the posts with rammed earth and stone.
- Ensure that you have the appropriate Flood Risk Activity Permit if you are planting or fencing near a main river, flood plain or flood defence structure. Alternatively, ensure you have the appropriate Ordinary Water Course Consent if you are carrying out works near an ordinary water course. What may be considered a ditch may be an ordinary watercourse, so consent may be required. As such, **the permit/consent (or confirmation that a permit/consent is not needed) should be retained and made available on request.** See Terms and Conditions for more details.
- Where Small Grants - Environment activities include the installation of access furniture such as stiles or gates on a Public Right of Way, it is your responsibility to ensure you obtain approval under Section 147 of the Highways Act, 1980, from the appropriate Highway Authority.

Example of a Post and Rail Fence

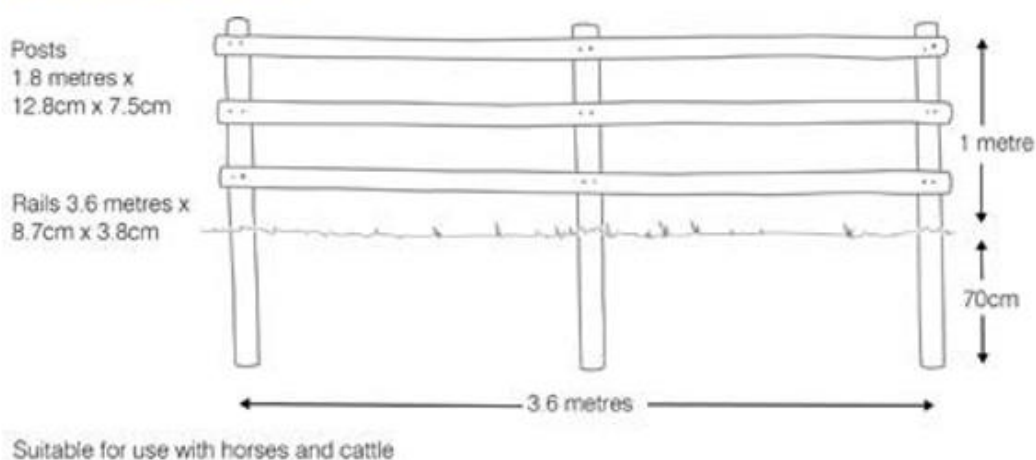

E594 Post and Wire Fencing

This technical note describes the minimum standard of work required in order to receive payments for 'Post and Wire Fencing'.

Any variation must be approved by the Welsh Government prior to starting the work.

You must adhere to the following:

- Ensure that you have obtained, and adhere to any licences, consents or permissions that are needed.
- Use fencing timber comprising either hardwood or pressure treated softwood.
- Ensure that timbers, wire, netting and galvanised staples consist of new materials.
- Attach at least three lines of wire made up of either galvanised mild steel wire (4mm gauge) or two ply twisted barbed wire (2.5mm gauge). The top wires of any fencing erected next to public access routes must consist of plain wire or an additional line of plain wire must be affixed to the outside of the posts closest to the route in question.
- Use straining posts that are a minimum of 12.5cm cross section and at least 2m long. Straining posts must be set into the ground at a sufficient depth to ensure stability. Straining posts must be placed at either end of the fence line and at centres of 100m or less, as well as at every horizontal or vertical change of direction.
- Attach struts at each end of the fence line and at all changes of slope and direction. Struts must have a top diameter of at least 6.5cm and must be supported to prevent them splaying outwards.
- Use intermediate posts that are at least 6.5cm diameter (round posts and sawn timber) and at

least 1.7m long. Half round posts are acceptable provided they measure at least 6.5cm from the midpoint of the sawn side to the mid-point of the round side. Intermediate posts must be set at centres of 3m or less.

- Attach wire to posts with galvanised staples.
- Attach the top wire no less than 1.05m from the ground.
- Ensure that the new fencing conforms to British Standards 1722 and 4102, as amended.

Example Diagram of Three Line Wire Fence

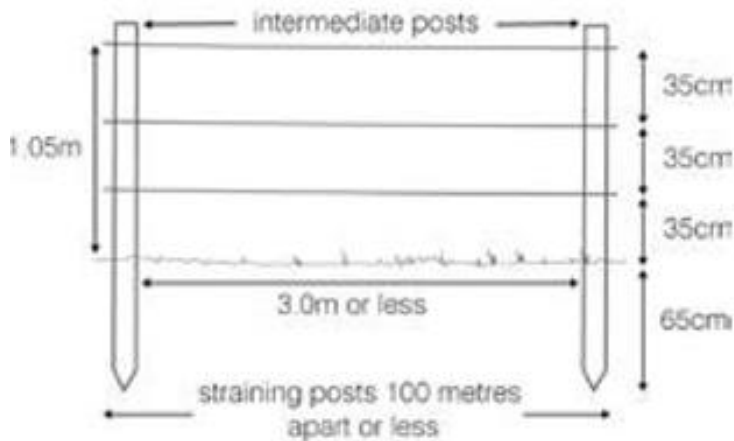

Do not:

- Use trees and shrubs as strainers or fencing posts, or attach wire, staples or netting to them.

Requirements and guidance in addition to the specifications above:

- Best practice is to set the posts at least 1m into the ground to ensure stability.
- Diagonal struts must be supported with either a base plate or a suitably positioned intermediate post to prevent them splaying outwards.
- Ensure that you have the appropriate Flood Risk Activity Permit if you are planting or fencing near a main river, flood plain or flood defence structure. Alternatively, ensure you have the appropriate Ordinary Water Course Consent if you are carrying out works near an ordinary water course. What may be considered a ditch may be an ordinary watercourse, so consent may be required. As such, **the permit/consent (or confirmation that a permit/consent is not needed) should be retained and made available on request.** See Terms and Conditions for more details.
- Where Small Grants - Environment activities include the installation of access furniture such as stiles or gates on a Public Right of Way, it is your responsibility to ensure you obtain approval under Section 147 of the Highways Act, 1980, from the appropriate Highway Authority.

E931 Post and Wire Fencing with Stock Netting

This technical note describes the minimum standard of work required in order to receive payment for 'Post and Wire Fencing with Stock Netting'. Any variation must be approved by the Welsh Government prior to starting the work.

You must adhere to the following:

- Ensure that you have obtained, and adhere to any licences, consents or permissions that are needed.
- Use fencing timber comprising either hardwood or pressure treated softwood.
- Ensure that timbers, wire, netting and galvanised staples consist of new materials.
- Use straining posts that are a minimum of 12.5cm cross section and at least 2m long. Straining

posts must be set into the ground at a sufficient depth to ensure stability. Straining posts must be placed at either end of the fence line and at centres of 100m or less, as well as at every horizontal or vertical change of direction.

- Attach struts at each end of the fence line and at all changes of slope and direction. Struts must have a top diameter of at least 6.5cm and must be supported to prevent them splaying outwards. Use intermediate posts that are at least 6.5cm diameter (round posts and sawn timber) and at least 1.7m long. Half round posts are acceptable provided they measure at least 6.5cm from the midpoint of the sawn side to the midpoint of the round side. Intermediate posts must be set at centres of 3m or less.
- Attach netting to posts with galvanised staples.
- Attach wire to posts with galvanised staples with the distance from the ground to the top wire no less than 1.05m. In cases where there is heavy pressure from sheep or cattle, a second line wire on top of the netting as well as an additional wire at the bottom should be added. The top wires of any fencing erected next to public access routes must consist of plain wire or an additional line of plain wire must be affixed to the outside of the posts closest to the route in question.
- Ensure that the new fencing conforms to British Standards 1722 and 4102, as amended.
- Use trees and shrubs as strainers or fencing posts, or attach wire, staples or netting to them.

Example Diagram of Post and Wire with Stock Netting

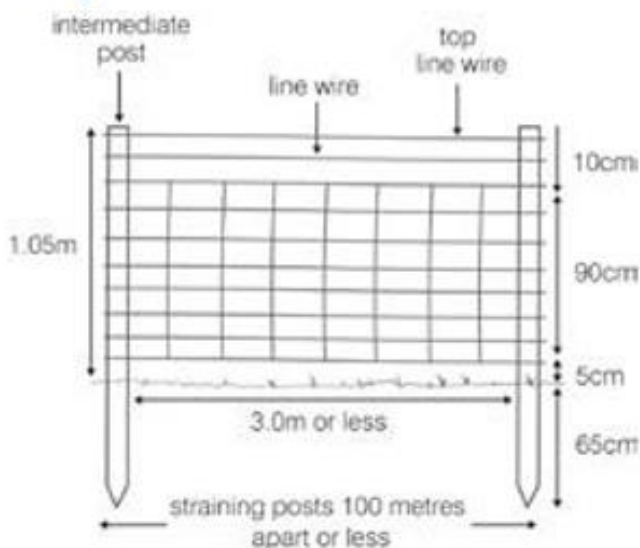

Requirements and guidance in addition to the specifications above:

- Best practice is to set the posts at least 1m into the ground to ensure stability.
- Diagonal struts must be supported with either a base plate or a suitably positioned intermediate post to prevent them splaying outwards.
- Ensure that you have the appropriate Flood Risk Activity Permit if you are planting or fencing near a main river, flood plain or flood defence structure. Alternatively, ensure you have the appropriate Ordinary Water Course Consent if you are carrying out works near an ordinary water course. What may be considered a ditch may be an ordinary watercourse, so consent may be required. As such, **the permit/consent (or confirmation that a permit/consent is not needed) should be retained and made available on request.** See Terms and Conditions for more details.
- Where Small Grants - Environment activities include the installation of access furniture such as stiles or gates on a Public Right of Way, it is your responsibility to ensure you obtain approval under Section 147 of the Highways Act, 1980, from the appropriate Highway Authority.

E932 Supplement for Rabbit Fence Netting

This option is supplementary and can only be used against the following options where they are also being installed:

E593 – Post and Rail Fence

E594 – Post and Wire Fence

E604 – Parkland Tree Guard

E931 – Post and Wire Fencing with Stock Netting

This technical note describes the minimum standard of work required in order to receive payments for ‘Supplement for Rabbit Fence Netting’. Any variation must be approved by the Welsh Government prior to starting the work.

Rabbit fencing can be specifically used to prevent damage to specific landscape features such as newly planted trees and hedgerows.

You must adhere to the following:

- Attach all wire and netting to posts with galvanised staples.
- Use galvanised wire netting at least 1.05m high, with a mesh no larger than 3cm.
- Ensure the top edge of the netting is at least 0.75m above ground level.
- Ensure that timbers, wire, netting and galvanised staples consist of new materials.
- Ensure that the netting is fastened to the fencing with the bottom edge of the netting buried in the ground to a sufficient depth to prevent rabbits burrowing underneath.
- Where required, fix strands of line wire to support the rabbit fence.
- Ensure any gates used in rabbit fences are appropriately proofed to prevent rabbit/hare access.
- Ensure that the new fence conforms to British Standards 1722 and 4102, as amended.

Do not:

- Use trees and shrubs as strainers or fencing posts, or attach wire, stables or netting to them.

Requirements and guidance in addition to the specifications above:

- Prevent rabbits burrowing underneath by ensuring that the netting is buried in the ground to a depth of 15cm and then turned outwards a further 15cm and anchored securely.
- Ensure that you have the appropriate Flood Risk Activity Permit if you are planting or fencing near a main river, flood plain or flood defence structure. Alternatively, ensure you have the appropriate Ordinary Water Course Consent if you are carrying out works near an ordinary water course. What may be considered a ditch may be an ordinary watercourse, so consent may be required. As such, **the permit/ consent (or confirmation that a permit/ consent is not needed) should be retained and made available on request.** See Terms and conditions for more details.
- Where Small Grants - Environment activities include the installation of access furniture such as stiles or gates on a Public Right of Way, it is your responsibility to ensure you obtain approval under Section 147 of the Highways Act, 1980, from the appropriate Highway Authority.

Example of Rabbit Fencing

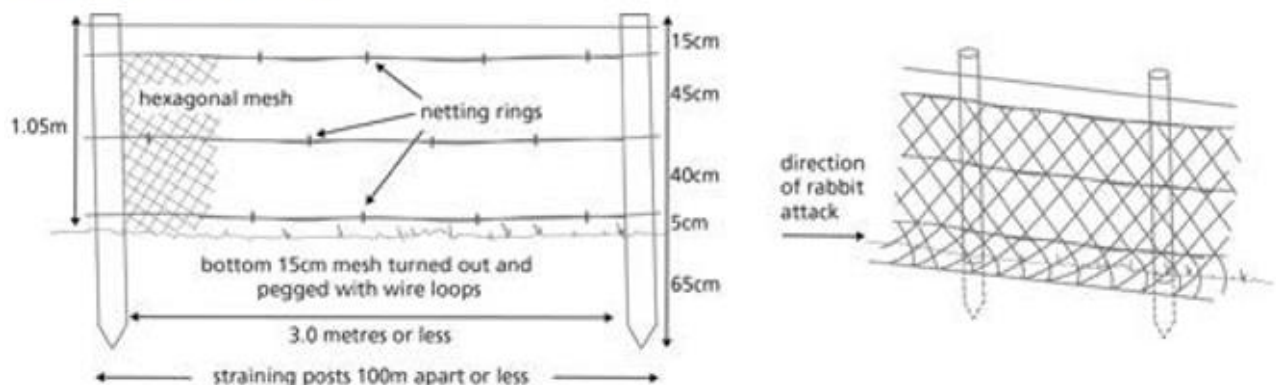

E599 Timber Field Gates (Hardwood)

This technical note describes the minimum standard of work required in order to receive payments for 'Timber Field Gates (Hardwood)'. Any variation must be approved by the Welsh Government prior to starting the work.

You must adhere to the following:

- Install timber field gates that are at least 2.4m wide, but no more than 4.2m wide. Any openings greater than 4.2m must have two leaves.
- Use timber field gates constructed from hardwood only, which complies with the dimensions set out in the diagram below.
- Use timber field gates that conform to the specifications set out in the diagram below as well as those of British Standard 3470, as amended.
- Hang gates on timber gate posts at least 2.1m long. Hanging posts must be at

least 200mm x 200mm in cross section. Shutting posts must be at least 175mm x 175mm in cross section.

- Set gateposts correctly into the ground, using concrete if necessary and fit with appropriate hangings and latches.

Do not:

- Use hanging or shutting posts as straining posts for fencing. A short length of split timber should be used to form a horizontal strut between the gate post and adjacent straining post.
- Use second hand material for constructing gates unless approved in advance by the Welsh Government.

Example of Timber Field Gate (Hardwood)

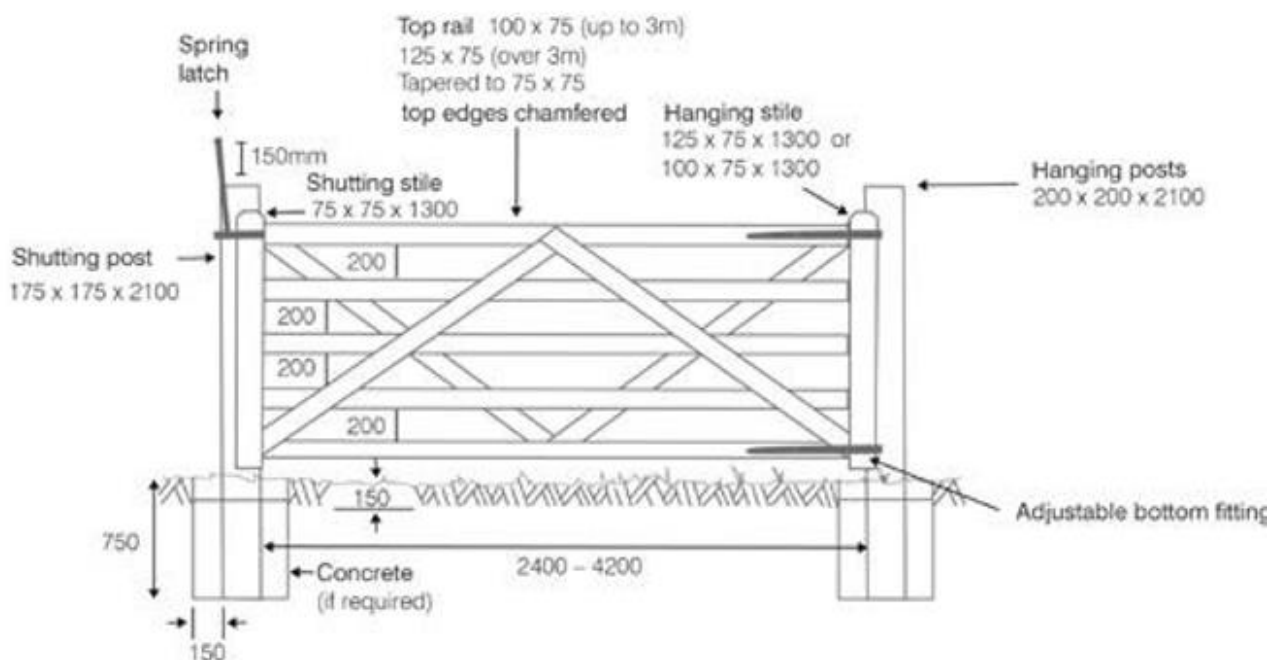

E600 Timber Field Gates (Softwood)

This technical note describes the minimum standard of work required in order to receive payments for 'Timber Field Gates (Softwood)'. Any variation must be approved by the Welsh Government prior to starting the work.

If any of the work claimed is found to have been carried out to a different standard, without the prior approval by Welsh Government, the project may be considered ineligible. This will result in claims being withheld (or recovered) with penalties applied in line with the scheme rules, unless work is assessed to have been delivered to an equivalent standard.

You must adhere to the following:

- Install timber field gates that are at least 2.4m wide, but no more than 4.2m wide. Any openings greater than 4.2m must have two leaves.

- Use timber field gates constructed from hardwood or pressure treated softwood, which complies with the dimensions set out in the diagram below.
- Use timber field gates that conform to the specifications set out in the diagram below as well as those of British Standard 3470, as amended posts must be at least 175mm x 175mm in cross section.
- Set gateposts correctly into the ground, using concrete if necessary and fit with appropriate hangings and latches.

Do not:

- Use hanging posts or shutting posts as straining posts for fencing. A short length of split timber should be used to form a horizontal strut between the gate post and adjacent straining post.
- Use second hand material for constructing gates unless approved in advance by the Welsh Government.

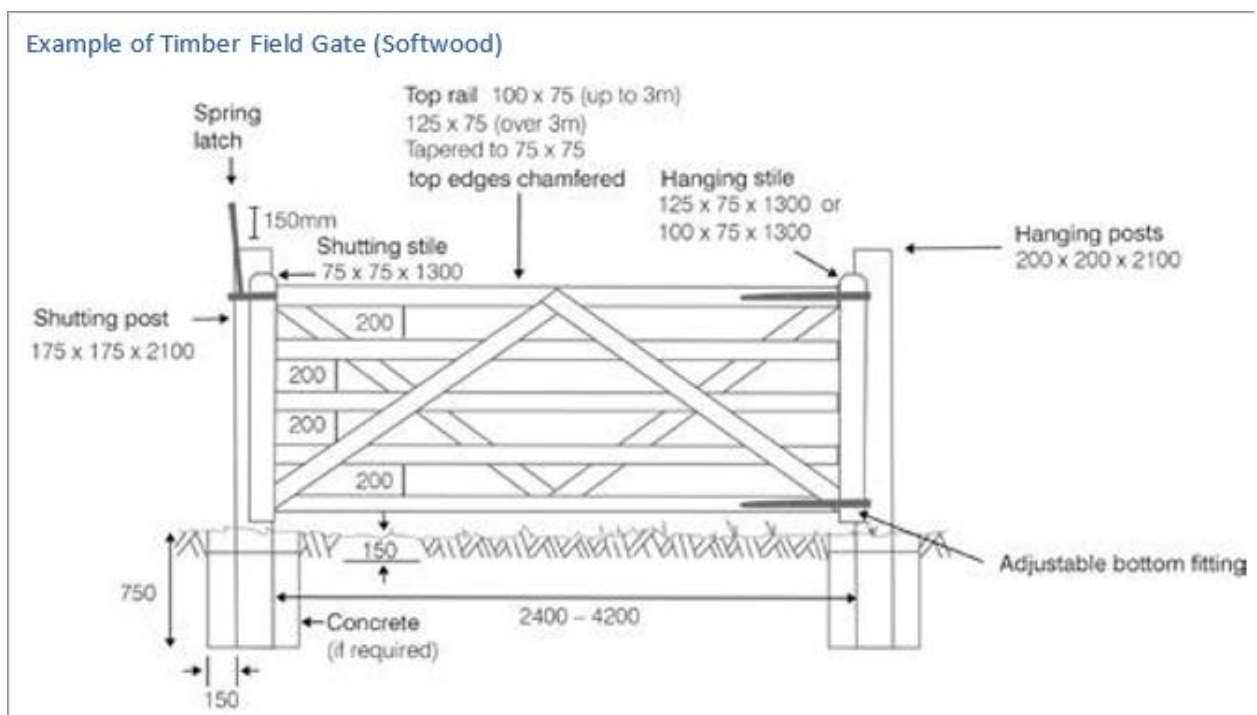

E608 Tree Shelter (60cm With Stake)

This technical note describes the minimum standard of work required in order to receive payments for 'Tree Shelter (60cm with stake)'. Any variation must be approved by the Welsh Government prior to starting the work.

Newly planted trees and shrubs only need protection where animals or machinery might damage them. Fencing will usually provide more economic protection for groups of trees and shrubs against machinery or large browsing animals, in combination with spiral rabbit guards to protect against rabbits and hares.

Individual tree shelters and stakes can also be used where lengths of fencing would be unsightly, for example in parklands.

You must adhere to the following:

- Insert a stake vertically into the ground next to each newly planted tree. The stake should have a diameter of 2.5cm x 2.5cm on sheltered sites and 3cm x 3cm on

more exposed sites.

- Fix all tree shelters to the stake with wire or plastic cable clips.
- Ensure that the stake is no taller than the shelter.

Do not:

- Allow weeds to grow inside the shelters.

Requirements and guidance in addition to the specifications above:

- Tree shelters to protect young trees are translucent plastic tubes up to 2m in height, with a diameter of up to 12cm. They are constructed of twin wall polypropylene.
- Each shelter should provide support and protection for some 5 -10 years before it bio-degrades.
- Although shelters come in a range of colours, there is little difference between them in terms of tree growth. When planting under established trees, where light intensity is likely to be low, it is generally better to use clear translucent tubes.
- Tree shelters need to be above the browse height of the animal. This can vary from 60cm for rabbits and hares, to 2m for Roe deer. Sheep can browse at 1.2m-1.5m high.
- The removal of weeds around trees and in shelters is crucial as the weeds can compete for nutrients and light. Trees in tree shelters must be weeded for the first 2-3 years of life. Weeds growing inside the tree shelter must also be removed. This can be done by lifting the shelter slightly and carefully pulling the weeds out from the tube by hand.
- Any plants that have been loosened or partly lifted by winds and winter frosts should be trodden back in carefully. Regularly inspect fencing, tree guards, stakes and tree ties (loosen tight ties as these will constrict tree growth) and prevent trees growing through or chafing against tree guards.

E647 Spiral Rabbit Guards

This technical note describes the minimum standard of work required in order to receive payments for ‘Spiral Rabbit Guards’.

Any variation must be approved by the Welsh Government prior to starting the work. Spiral rabbit guards are the most widely used form of tree protection against rabbits and voles.

You must adhere to the following:

- Ensure each spiral rabbit guard is supported by a bamboo cane.

Do not:

- Use guards that are taller than the tree it is to protect at the time of planting.
- Requirements and guidance in addition to the specifications above:
- Spiral rabbit guards are made from a plastic material and are available in three sizes, (45cm, 60cm and 75cm).
- Ideally the bamboo cane should be pushed into the ground next to the newly planted tree. The guard is then wound or spiralled around both tree and cane so that small mammals are excluded.

E905 Bramble/Scrub Control – Hand-held or Knapsack Spraying

This technical note describes the minimum standard of work required in order to receive payments for control of 'Bramble/ Scrub Control – Hand-held or Knapsack Spraying'. Any variation must be approved by the Welsh Government prior to starting the work.

Bramble is a successful and invasive native species. It can produce dense thickets and can have a negative impact on other vegetation. Bramble will prevent new trees from establishing, so will have to be cleared before tree planting takes place. Before using pesticides (including herbicides) always consider whether control can be undertaken using non-chemical measures.

You must adhere to the following:

- Treat a sufficient area of bramble to allow tree planting to be carried out and the trees to establish unhindered by bramble.
- Ensure you use a product approved for hand-held or knapsack application on bramble/scrub. Product labels should be adhered to, retained and made available on request.
- Anyone applying plant protection products (pesticides) as part of their work must hold a recognised specified training certificate. Users, or those who cause or permit use, must ensure that all reasonable precautions are taken to protect human health and the environment, applications are confined to target areas and the amount used and frequency of use is as low as reasonably practicable.

Requirements and guidance in addition to the specifications above:

Do not:

- Use a knapsack to control vegetation higher than waist height, or for clearing large areas. It will be tiring to keep the boom above the bramble and coverage will be impaired.
- All manufactures label recommendations regarding herbicide application should be strictly adhered to.

More useful information may be found at the following locations:

[Code of Practice for Using Plant Protection Products \(hse.gov.uk\)](https://www.hse.gov.uk) UKFS Guidelines:

General Forest Practice www.forestry.gov.uk/ukfs

Use of Herbicides

In all cases, the herbicide used must have a label recommendation for your intended use, and for the intended method of application.

E933 Bracken Control (Mechanical Two Cuts/Year)

This technical note describes the minimum standard of work required in order to receive payments for 'Bracken control (Mechanical cutting)'. Any variation must be approved by the Welsh Government prior to starting the work.

Bracken is a vigorous perennial fern which grows from an underground rhizome system. Above ground, bracken fronds are fully open from about mid-June to August and it is at this time that the plants have deployed most of their nutrient reserves. This option is available to clear areas of bracken so that ground flora can develop or to allow new trees and hedgerows to be established. This option is preferred where chemical control of bracken is not appropriate.

You must adhere to the following:

- Control the bracken by bruising, crushing or cutting only.
- Control bracken at least twice during the growing season. Additional guidance on the best time to control bracken is listed below.

Do not:

- Control bracken using chemicals such as 'Asulam'.
- Control bracken by burning.

Requirements and guidance in addition to the specifications above:

- Crushing and cutting should be timed so that the fully extended frond is taken out before the plant has time to translocate food reserves from the frond back to the rhizome. The plant has expended considerable food reserves in producing the frond and well-timed removal causes substantial weakening. The period from May to mid-August will generally be the best time to crush or cut depending on weather conditions.
- This method is strongly recommended, especially where it is necessary to avoid chemical damage to water courses or sensitive plants such as other ferns.
- Cutting should ideally be followed up by grazing of heavy stock such as cattle before tree planting, since this will help to prevent frond regrowth.
- It is important to bear in mind that stands of bracken can contribute to landscape diversity and may well be of considerable value to wildlife in their own right. Where intermixed with scattered trees and shrub, bracken is often important for birds such as whinchat, yellowhammer and nightjar. Open bracken with an understorey of violets may support populations of fritillary butterflies. Even dense stands with heavy litter may provide cover for overwintering birds of prey such as hen harrier and short eared owl, as well as mammals such as bank vole, badger and deer.