



Llywodraeth Cymru  
Welsh Government

# Small Grants – Woodland Creation (window 5) **Technical Guidance**

## Contents

Introduction .....	3
<b>SECTION A – SITE ASSESSMENT .....</b>	<b>4</b>
Type of land eligible for support .....	4
Type of land not eligible for support .....	5
Sites of Importance for Nature Conservation (SINC) .....	6
Consents, permissions, and other considerations .....	6
Public rights of way .....	6
Overhead or Underground utilities .....	6
Planting near main rivers, streams and ponds .....	7
Main rivers .....	7
Ordinary watercourses .....	8
Evidence of Badgers .....	8
Hedgerows, stonewalls and earth banks included or adjacent to planting .....	8
Red Squirrel Guidance Areas .....	9
Areas within Denbighshire and Conwy .....	9
Areas within Ceredigion, Powys and Carmarthenshire .....	10
Protection from deer .....	10
Existing Trees .....	10
Planting adjacent to a non-agricultural building .....	11
<b>SECTION B – WOODLAND CATEGORY AND SPECIES MIX .....</b>	<b>12</b>
SW01 - Native Biodiversity 1100 Species Mixture .....	13
SW02 - Native Biodiversity 1600 Species Mixture .....	14
SW03 - Native Shelterwood Species Mixture .....	15
SW04 - Red Squirrel 1600 Species Mixture .....	16
SW05 - Red Squirrel 2500 Species Mixture .....	17
SW09 - Shelterwood (Productive) Species Mixture .....	18
SW10 - Wet Woodland and Streamside 1100 Species Mixture .....	19
SW11 - Wet Woodland and Streamside 1600 Species Mixture .....	20
SW12 - Wood Fuel (Productive) Species Mixture .....	21
<b>SECTION C - CAPITAL WORKS SPECIFICATIONS .....</b>	<b>22</b>
Methods of Planting .....	22
SW06 - Post and Wire Fencing with Stock Netting .....	23
SW07 - Timber Bridle Gate and Posts .....	24
SW08 - Timber Kissing Gate and Posts .....	26
SW13 – Deer Fencing .....	27

# Small Grants – Woodland Creation

## Technical Guidance

### Introduction

Small Grants – Woodland Creation is a scheme aimed at farmers and other land managers to encourage planting of small areas of trees on land which is agriculturally improved or low environmental value in Wales.

Funding is available for tree planting, fencing and gates to create shelterwoods, alongside watercourses, and in field corners or small fields for stock shelter, biodiversity and woodfuel. Small Grant – Woodland Creation also offers 12 years of Maintenance and Premium payment in respect of the new planting. The application process provides a way of ensuring planting proposals meet the UK Forestry Standard (UKFS) requirements without the need for verification of a woodland creation plan by NRW. Funding is available for planting areas between 0.1ha and 1.99ha.

This scheme offers support for planting on the low sensitivity area shown on the Woodland Opportunities Map (WOM) [datamap.gov.wales/maps/small-grants-woodland-creation/](https://datamap.gov.wales/maps/small-grants-woodland-creation/) only. This excludes priority habitats as well as land above the upper limit of enclosure and common land due to potential landscape impact and other complexities. You should check that the areas you are proposing are on the low sensitivity area before going any further. If not, you will be ineligible for the [Small Grants – Woodland Creation](#) scheme and will need to apply to the [Woodland Creation Planning Scheme](#).

# SECTION A – SITE ASSESSMENT

Before you complete your expression of interest you will need to carry out a site assessment of your proposed area for planting. The assessment will help you gather information about the suitability of your location and to develop proposals for your application.

## Type of land eligible for support

To protect potentially sensitive habitats, you will need to confirm the area to be planted has been agriculturally improved or is of low environmental value. Photographs giving examples of the types of land eligible for support are shown below. These include areas where agricultural improvement may have occurred some years ago and the land is not species rich.

Improved upland or hill grazing



Areas of bracken or rush with little species diversity (including under bracken)



Areas of productive lowland type grazing (may include patches of nettles/thistles)



## Type of land not eligible for support

You will need to establish if there are any Priority Habitats or Sites of Importance for Nature Conservation where you wish to plant trees, as these areas will not be eligible for support. You may still be able to apply to the Woodland Creation Planning Scheme instead so that a woodland creation plan can be developed with support from a registered Woodland Planner.

The following photographs are intended as a guide to potential priority habitats that are not eligible for support. If you are in doubt whether the land is priority habitat you should seek advice or consider applying to the Woodland Creation Planning Scheme.

Flower rich hay-meadows and pastures



(Courtesy of Natural Resources Wales)

Areas of rush with high levels of flowering broad-leaved plants



Heaths including patches of heather - often purple in late summer.



Tussocky grass, often wet and unpalatable to livestock



### **Sites of Importance for Nature Conservation (SINC)**

Sites of Importance for Nature Conservation (SINC) are designated by Local Authorities. If you are aware of any such sites on your land, these are ineligible for the Small Grants – Woodland Creation scheme. If you wish to plant on these areas you will need to consider applying to the Woodland Creation Planning Scheme (WCPS).

### **Consents, permissions, and other considerations**

#### **Public rights of way**

Owners or occupiers of land with a public right of way across it must keep the route visible and not obstruct or endanger users. Local authorities are responsible for the management of public rights of way. Small Grants – Woodland Creation works must not lead to an obstruction or cause a danger to the public. You should consult your Local Planning Authority if any Capital Works require gates or signs to ensure the right of way remains open and fit for use. Where public rights of way are confirmed, conditions will be included in the contract.

You must ensure that any work carried out under Small Grants – Woodland Creation is compliant with your responsibility on public rights of way (PRoW). Where fencing is required across a PRoW you will need to contact your Local Authority for authorisation for your proposals for fencing and gates. Specification for fencing and gates supported by the Small Grants – Woodland Creation scheme are given at the end of this Technical Guidance booklet. Where public rights of way are confirmed, conditions will be included in the contract which you will need to observe.

#### **Overhead or Underground utilities**

As part of the application process you will need to indicate if there are any overhead or underground utilities within the proposed area. The following websites can help identify any overhead or underground utilities you may not be aware of –

[Wales and West Utilities: gas connections & services \(selectra.co.uk\)](http://selectra.co.uk)

[Western Power Distribution - Check before you dig - location of our cables and equipment](#)

Where you confirm you have overhead or underground utilities within the planting area, conditions will be included in the contract which you will need to observe.

### **Planting near main rivers, streams and ponds**

The Wet Woodland and Streamside category (1100 or 1600 trees/ha) must be used for any planting within 20m of a permanent watercourse or pond – see Species Choice section. The category is also appropriate for wetter areas and springs.

You should leave an unplanted buffer of at least 15m on the south side of a pond, otherwise shading could cause deterioration in the pond. You should ensure rides/paths are planned to enable appropriate access for maintenance.

Work including tree planting, fences or gates on or near a watercourse are likely to need permission. The type of permission depends on whether the watercourse is designated a main river or an ordinary watercourse.

### **Main rivers**

A main river is legally defined as a watercourse shown on the main rivers map – see [Natural Resources Wales / Environmental permits for flood risk activities](#) . Main rivers have been designated due to the importance of managing flood risk. Note, even small watercourses may be classed as main rivers.

If applicants want to carry out works in, over, under or near (within 8 metres of) a main river or flood defence (including a sea defence), or within a flood plain, they may need to apply for Flood Risk Activity Permit (FRAP). This can be obtained from Natural Resources Wales (NRW) to ensure activities do not cause a risk of flooding or make existing flood risk worse. A permit is also necessary to ensure work will not interfere with NRW flood risk infrastructure or adversely affect the local environment, fisheries or wildlife.

NRW determine FRAP applications to manage flood risk by regulating works and development activities. Certain activities will be permitted in, over, under or adjacent to a main river without charge and without needing a permit, providing certain conditions are met. These activities are classed as exemptions or exclusions: All remaining activities will require a bespoke FRAP.

If applicants do not apply for a FRAP, the consequences could be expensive. NRW can reclaim the costs of putting things right and applicants could also be prosecuted. The Welsh Government may also withhold or recover payments.

## Ordinary watercourses

If the watercourse is not a main river, it could be an ordinary watercourse. SG-WC Capital Works will not cause an obstruction to flow, restrict storage or involve erecting a culvert, so do not require Ordinary Watercourse Consent.

Where planting near main rivers, streams and ponds, conditions will be included in the contract which you will need to observe.

## Evidence of Badgers

Look for evidence such as footprints, hair on fences or spoil heaps. The photographs below give examples of what to look for.

Where evidence of badgers is confirmed, conditions will be included in the contract which you will need to observe to protect a known badger sett.

Badger hair on barbed wire or badger sett spoil heaps



## Hedgerows, stonewalls and earth banks included or adjacent to the proposed planting

Boundary features such as hedgerows, stonewalls and earth banks provide habitat connectivity, landscape character and can often provide important information about historical land use and farming practices. This includes 'old' redundant hedgerows such as the one pictured below. Earth banks can vary in size from subtle, difficult to detect features, to substantial ramparts. They may indicate settlement areas or boundaries. The latter may have other boundary markers such as old trees, hedges or stones.

Where planting includes or is adjacent to hedgerows, stonewalls or earth banks, conditions will be included in the contract not to plant broadleaves within 2m and conifers within 5m of such boundaries.





## Red Squirrel Guidance Areas

Planting proposals in Red Squirrel areas must use the Red Squirrel category (1600 or 2500 trees/ha), unless within 20m of permanent watercourse when the Wet Woodland and Streamside category (1100 or 1600 trees/ha) should be used.

The red squirrel guidance areas below indicate where both red and grey squirrels live, and as such new woodland creation needs to be planned to favour the native species. Red squirrel areas where grey squirrels are no longer present (such as Anglesey) are not included.

There are two areas, one in the north covering parts of Denbighshire and Conwy, and one in mid Wales covering parts of Ceredigion, Powys and Carmarthenshire. Further information is available from [Squirrels Map - Red Squirrels Trust Wales](#)

### Areas within Denbighshire and Conwy



## Areas within Ceredigion, Powys and Carmarthenshire



### Protection from deer

Deer is a serious problem on planting sites where they are present in large numbers. Some planting situations may require deer guards to be fitted to the trees; these tend to be large and relatively expensive and may stand out in the landscape.

Where the proposed planting will require protection from deer, you may need to use deer fencing – see specification SW13 in Section 3 – Capital Works Specifications.

### Existing Trees

Existing trees (diameter of 8cm or over) and scrub (areas of poorly formed trees or bushes unsuitable for conversion to timber) have a high environmental value and should not be cleared for new planting but should be incorporated in the planting design up to a maximum of 15%. The total number of trees planted in the plot must match the prescribed planting density. Where there are existing trees and shrubs, trees should be planted closer together in the remainder of the plot to achieve the planting density. The minimum distance between trees should be no less than 1 metre. Where the proposed planting includes existing trees, conditions will be included in the contract.

Note that significant blocks of three or more existing trees (SAF crop codes ZZ10 and ZZ11) will be excluded from the eligible area for this scheme.

## **Planting adjacent to a non-agricultural building**

Tree planting adjacent to residential or commercial properties can have a detrimental impact if not fully considered. If you intend to plant next to a non-agricultural building it is better to engage a registered woodland planner through the Woodland Creation Planning Scheme.

Where the proposed planting is adjacent to a non-agricultural building conditions will be included in the contract.

## SECTION B – WOODLAND CATEGORY AND SPECIES MIX

The tree species mixtures for each Woodland Category allowed under Small Grants – Woodland Creation are detailed in the following tables, along with outcomes and criteria for planting. If you wish to use other species or mixes you will need to apply to the Woodland Creation Planning Scheme.

It will be important to consider the physical characteristics of the area you wish to plant and your objectives for woodland creation. You should consider whether one Woodland Category will suit the whole area, or whether the area should be sub-divided into areas of the same type. For example you may have a wetter area at the bottom of a slope where the Wet Woodland and Streamside category (1100 or 1600 trees/ha) is suitable, and an adjoining drier bank where you may wish to use the Native Shelterwood category. The areas to be planted with different Woodland Categories will need to be indicated on a map as part of the on-line application process.

The Wet Woodland and Streamside category (1100 or 1600 trees/ha) is essential for all areas within 20m of a watercourse and can also be used on wetter ground away from watercourses. The Red Squirrel (1600 or 2500 trees/ha) category is essential within the Red Squirrel Guidance areas but can also be used elsewhere.

**You must choose one or more species from each of the six columns in the species mix tables, and the percentage of the mix for each column is also given in the table. This will enable you to calculate the number of trees of each species you will need as in the following example.**

Planting Area (ha)	Code	Woodland Category	Species and required %	Density	Number of trees of each species to be planted
1.20ha	SW11	Wet Woodland and Streamside Species Mixture 1600	Native willow species 30%; Native Birch species 20%; Aspen and/or Elder 20%; Common alder 10%; Bird Cherry, Guelder Rose and/or Black Poplar 10%; Hawthorn and/or Blackthorn 10%	1,600/ha	Native Willow species 576; Native Birch species 384; Aspen and/or Elder 384; Common alder 192; Bird Cherry, Guelder Rose and/or Black Poplar 192; Hawthorn and/or Blackthorn 192

You are advised to responsibly source planting stock through nurseries or suppliers that adhere to national standards such as the [Plant Health Management Standard](#), or

that have their own biosecurity policy in place that you trust. Also, to specify British-grown plants when sourcing planting stock, to reduce the risk of an accidental introduction of invasive non-native pests or diseases.

The level of protection required to enable trees to establish will vary depending on the site being planted. In some cases, tree guards will not be required, but where they are considered necessary, we would encourage land managers to consider the use of non-plastic alternatives if appropriate for the site conditions.

## SW01 - Native Biodiversity 1100 Species Mixture

### Outcome

- Connect areas of woodland and provide varied age structure for biodiversity
- Store Carbon in trees and soil
- Grow trees for biomass and firewood e.g. biomass burners
- Supports farm diversification
- Reduces farm business dependence on buying in biomass or firewood
- Protects farmers against price volatility of timber

### Criteria

- 100% broadleaves (including up to 30% woody shrubs).
- Average density of 1,100 trees/ha
- Where possible plant next to existing woodland and hedges
- Minimise use of herbicide
- Manual planting or mechanical mounding/screefing
- Leave at least 1 metre gap from any fence (new or existing)

<b>Select at least ONE species from each column</b>					
<b>Species 1</b> (30%)	<b>Species 2</b> (20%)	<b>Species 3</b> (20%)	<b>Species 4</b> (10%)	<b>Species 5</b> (10%)	<b>Species 6</b> (10%)
Downy birch Sessile oak	Pendunculate oak Silver birch Hazel*	Crab apple Field maple Aspen	Native willow species Alder	Wild cherry Bird cherry Rowan	Hawthorn* Holly* Blackthorn*

\* Woody shrubs

## SW02 - Native Biodiversity 1600 Species Mixture

### Outcome

- Connect areas of woodland and provide varied age structure for biodiversity
- Store Carbon in trees and soil
- Grow trees for biomass and firewood e.g. biomass burners
- Supports farm diversification
- Reduces farm business dependence on buying in biomass or firewood
- Protects farmers against price volatility of timber

### Criteria

- 100% broadleaves (including up to 30% woody shrubs).
- Average density of 1,600 trees/Ha
- Where possible plant next to existing woodland and hedges
- Minimise use of herbicide
- Manual planting or mechanical mounding/screefing
- Leave at least 1 metre gap from any fence (new or existing)

<b>Select at least ONE species from each column</b>					
<b>Species 1</b> (30%)	<b>Species 2</b> (20%)	<b>Species 3</b> (20%)	<b>Species 4</b> (10%)	<b>Species 5</b> (10%)	<b>Species 6</b> (10%)
Downy birch Sessile oak	Pendunculate oak Silver birch Hazel*	Crab apple Field maple Aspen	Native willow species Alder	Wild cherry Bird cherry Rowan	Hawthorn* Holly* Blackthorn*

\* Woody shrubs

## SW03 - Native Shelterwood Species Mixture

### Outcome

- Provide shade and shelter for stock in adjoining fields
- Extend grazing season
- Improve condition of stock
- Improve farm biosecurity
- Connect areas of woodland and provide varied age structure for biodiversity
- Store Carbon in trees and soil

### Criteria

- 100% broadleaves (including up to 30% woody shrubs);
- Average density of 2,500 trees/Ha to improve impact of shelterwood
- Minimise use of herbicide
- Manual planting or mechanical mounding/screefing
- Leave at least 1 metre gap from any fence (new or existing)

<b>Select at least ONE species from each column</b>					
<b>Species 1</b> (30%)	<b>Species 2</b> (20%)	<b>Species 3</b> (20%)	<b>Species 4</b> (10%)	<b>Species 5</b> (10%)	<b>Species 6</b> (10%)
Downy birch Sessile oak	Pendunculate oak Silver birch	Native willow species Hazel*	Wild cherry Bird cherry Rowan	Field maple Small leaved lime Crab apple	Hawthorn* Holly* Blackthorn*

\* Woody shrubs

## SW04 - Red Squirrel 1600 Species Mixture

### Outcome

- Suitable for Red Squirrel areas.
- Stores Carbon in trees and soil
- Grow trees for timber
- Protects farmers against price volatility of timber
- Grow trees for biomass and firewood e.g. biomass burners
- Connect areas of woodland and provide varied age structure for biodiversity
- Supports farm diversification
- Reduces farm business dependence on buying in biomass or firewood

### Criteria

- 10% woody shrubs
- 70% native broadleaf
- Average density of 1,600 trees/Ha
- Minimise use of herbicide
- Manual planting or mechanical mounding/screefing
- Leave at least 1 metre gap from any fence (new or existing)

#### Select at least ONE species from each column

Species 1 (30%)	Species 2 (20%)	Species 3 (20%)	Species 4 (10%)	Species 5 (10%)	Species 6 (10%)
Native birch species	Scots pine (C) Norway spruce (C)	Aspen Wild cherry	Lodgepole pine (C) Sitka spruce (C)	Field maple Rowan	Hawthorn* Holly* Blackthorn* Guelder rose*

(C) conifer

\* Woody shrubs



## SW05 - Red Squirrel 2500 Species Mixture

### Outcome

- Suitable for Red Squirrel areas
- Stores Carbon in trees and soil
- Grow trees for timber
- Protects farmers against price volatility of timber
- Grow trees for biomass and firewood e.g. biomass burners
- Connect areas of woodland and provide varied age structure for biodiversity
- Supports farm diversification
- Reduces farm business dependence on buying in biomass or firewood

### Criteria

- 10% woody shrubs
- 70% native broadleaf
- Average density of 2,500 trees/Ha
- Minimise use of herbicide
- Manual planting or mechanical mounding/screefing
- Leave at least 1 metre gap from any fence (new or existing)

<b>Select at least ONE species from each column</b>					
<b>Species 1</b> (30%)	<b>Species 2</b> (20%)	<b>Species 3</b> (20%)	<b>Species 4</b> (10%)	<b>Species 5</b> (10%)	<b>Species 6</b> (10%)
Native birch species	Scots pine (C) Norway spruce (C)	Aspen Wild cherry	Lodgepole pine (C) Sitka spruce (C)	Field maple Rowan	Hawthorn* Holly* Blackthorn* Guelder rose*

(C) conifer

\* Woody shrubs

## SW09 - Shelterwood (Productive) Species Mixture

### Outcome

- Provide shade and shelter for stock in adjoining fields
- Extend grazing season
- Improve condition of stock
- Improve farm biosecurity
- Connect areas of woodland and provide varied age structure for biodiversity
- Store Carbon in trees and soil
- Grow trees for timber, biomass and firewood e.g. biomass burners
- Supports farm diversification
- Improves farm self sufficiency
- Protects farmers against price volatility

### Criteria

- Up to 45% conifers
- 15% woody shrubs
- Average density of 2,500 trees/Ha to improve impact of shelterwood
- Minimise use of herbicide
- Manual planting or mechanical mounding/screefing
- Leave at least 1 metre gap from any fence (new or existing)

<b>Select at least ONE species from each column</b>					
<b>Species 1</b> (30%)	<b>Species 2</b> (20%)	<b>Species 3</b> (20%)	<b>Species 4</b> (5%)	<b>Species 5</b> (10%)	<b>Species 6</b> (15%)
Sessile oak Downy birch	Sitka spruce (C) Silver birch Pedunculate oak	Norway spruce (C) Douglas fir (C)	Western Red Cedar (C) Scots pine (C)	Wild cherry Bird cherry Rowan	Hawthorn* Holly* Blackthorn*

\* Woody shrubs

C - conifers

## SW10 - Wet Woodland and Streamside 1100 Species Mixture

### Outcome

- Improve water quality
- Reduce surface water run off – slow the flow
- Reduce soil erosion
- Connect areas of woodland for biodiversity
- Create more dappled shade along watercourses
- Store carbon in trees and soil
- Stock management and biosecurity

### Criteria

- 100% site native broadleaves including up to 20% woody shrubs
- Use this option if within 20m of permanent watercourse or pond
- 1,100 trees/Ha with non-uniform spacing – some trees close together with gaps between small clumps of trees
- Establish and maintain a variable, predominantly open woodland canopy with half the watercourse open to sunlight and the remainder under dappled shade
- Leave 1m open ground at the water edge for bank side vegetation
- No herbicide/pesticide use
- Manual planting only
- Leave at least 1 metre gap from any fence (new or existing)

<b>Select at least ONE species from each column</b>					
<b>Species 1</b> (30%)	<b>Species 2</b> (20%)	<b>Species 3</b> (20%)	<b>Species 4</b> (10%)	<b>Species 5</b> (10%)	<b>Species 6</b> (10%)
Native willow species	Native birch species	Aspen Elder	Common alder	Bird cherry Guelder rose* Black poplar	Hawthorn* Blackthorn*

\* Woody shrubs

## SW11 - Wet Woodland and Streamside 1600 Species Mixture

### Outcome

- Improve water quality
- Reduce surface water run off – slow the flow
- Reduce soil erosion
- Connect areas of woodland for biodiversity
- Create more dappled shade along watercourses
- Store carbon in trees and soil
- Stock management and biosecurity

### Criteria

- 100% site native broadleaves including up to 20% woody shrubs
- Use this option if within 20m of permanent watercourse or pond
- 1,600 trees/Ha with non-uniform spacing – some trees close together with gaps between small clumps of trees
- Establish and maintain a variable, predominantly open woodland canopy with half the watercourse open to sunlight and the remainder under dappled shade
- Leave 1m open ground at the water edge for bank side vegetation
- No herbicide/pesticide use
- Manual planting only
- Leave at least 1 metre gap from any fence (new or existing)

<b>Select at least ONE species from each column</b>					
<b>Species 1</b> (30%)	<b>Species 2</b> (20%)	<b>Species 3</b> (20%)	<b>Species 4</b> (10%)	<b>Species 5</b> (10%)	<b>Species 6</b> (10%)
Native willow species	Native birch species	Aspen Elder	Common alder	Bird cherry Guelder rose* Black poplar	Hawthorn* Blackthorn*

\* Woody shrubs

## SW12 - Wood Fuel (Productive) Species Mixture

### Outcome

- Stores Carbon in trees and soil
- Grow trees for timber
- Protects farmers against price volatility of timber
- Grow trees for biomass and firewood e.g. biomass burners
- Connect areas of woodland and provide varied age structure for biodiversity
- Supports farm diversification
- Reduces farm business dependence on buying in biomass or firewood

### Criteria

- Up to 45% conifers
- Up to 35% woody shrubs
- Average density of 2,500 trees/Ha
- Minimise use of herbicide
- Manual planting or mechanical mounding/screefing
- Leave at least 1 metre gap from any fence (new or existing)

<b>Select at least ONE species from each column</b>					
<b>Species 1</b> (30%)	<b>Species 2</b> (20%)	<b>Species 3</b> (20%)	<b>Species 4</b> (5%)	<b>Species 5</b> (10%)	<b>Species 6</b> (15%)
Sessile oak Downy birch	Sitka spruce (C) Hazel* Native willow species	Norway spruce (C) Douglas fir (C) Silver birch	Western Red Cedar (C) Scots pine (C)	Wild cherry Bird cherry Rowan	Hawthorn* Holly* Blackthorn*

\* Woody shrubs

C - conifers

# SECTION C - CAPITAL WORKS SPECIFICATIONS

## Methods of Planting

Planting must be carried out using manual planting, scarification, or inverted & hinge mounding. If you intend to carry out your proposed planting using an alternative method, your expression of interest will be ineligible.

**Manual planting** - refers to using a planting spade to make a notch in which to plant a tree. The type of notch will depend on the soil conditions and the size of tree. The simple “V” notch is often suitable for smaller bare-root stock; “L” and “T” notches may work better for tree stock which has larger roots.

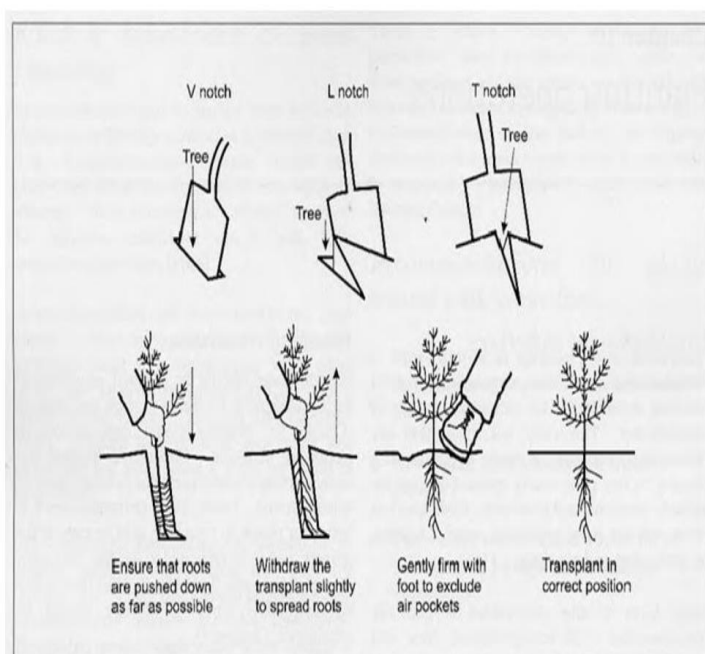

**Scarification** is the shallow cultivation of topsoil, including moving away any debris and vegetation, prior to planting. When mechanised, this is done in rows with spacing corresponding to the required tree stocking density. A manual alternative is screefing which involves moving the topsoil with (depending on the difficulty of the site) the planting spade, the heel of a boot, a mattock or a grub hoe. **Mechanised scarification cannot be used for Wet Woodland and Streamside 1100 and 1600.**

**Inverted mounding** uses machinery to turn over the surface layers to a depth of about 20cm. The extracted material is placed back in the hole that it came from. **Cannot be used for Wet Woodland and Streamside 1100 and 1600.**

**Hinge mounding** uses machinery and the mound of earth turned over is placed next to the hole, with the vegetation acting as the hinge. **Cannot be used for Wet Woodland and Streamside 1100 and 1600.**

## **SW06 - Post and Wire Fencing with Stock Netting**

These are the minimum standards of work required in order to be eligible to receive payment for 'Post and Wire Fencing with Stock Netting'.

You must adhere to the following:

- Ensure that you have obtained, and adhere to any licences, consents or permissions that are needed.
- Use fencing timber comprising either hardwood or pressure treated softwood.
- Ensure that timbers, wire, netting and galvanised staples consist of new materials.
- Use straining posts that are a minimum of 12.5cm cross section and at least 2m long. Straining posts must be set into the ground at a sufficient depth to ensure stability. Straining posts must be placed at either end of the fence line and at centres of 100m or less, as well as at every horizontal or vertical change of direction.
- Attach struts at each end of the fence line and at all changes of slope and direction. Struts must have a top diameter of at least 6.5cm and must be supported to prevent them splaying outwards. Use intermediate posts that are at least 6.5cm diameter (round posts and sawn timber) and at least 1.7m long. Half round posts are acceptable provided they measure at least 6.5cm from the midpoint of the sawn side to the midpoint of the round side. Intermediate posts must be set at centres of 3m or less.
- Attach netting to posts with galvanised staples.
- Attach wire to posts with galvanised staples with the distance from the ground to the top wire no less than 1.05m. In cases where there is heavy pressure from sheep or cattle, a second line wire on top of the netting as well as an additional wire at the bottom should be added. The top wires of any fencing erected next to public access routes must consist of plain wire or an additional line of plain wire must be affixed to the outside of the posts closest to the route in question.
- Ensure that the new fencing conforms to British Standards 1722 and 4102, as amended.
- Use trees and shrubs as strainers or fencing posts, or attach wire, staples or netting to them.

### **Requirements and guidance in addition to the specifications above**

- Best practice is to set the posts at least 1m into the ground to ensure stability.
- Diagonal struts must be supported with either a base plate or a suitably positioned intermediate post to prevent them splaying outwards.
- Ensure that you have the appropriate Flood Risk Activity Permit if you are planting or fencing near a main river, flood plain or flood defence structure. As such, the permit/consent (or confirmation that a permit/consent is not needed) should be retained and made available on request. See Terms and Conditions for more details.

- Where Small Grants - Woodland Creation activities include the installation of access furniture such as stiles or gates on a Public Right of Way, it is your responsibility to ensure you obtain approval under Section 147 of the Highways Act, 1980, from the appropriate Highway Authority.

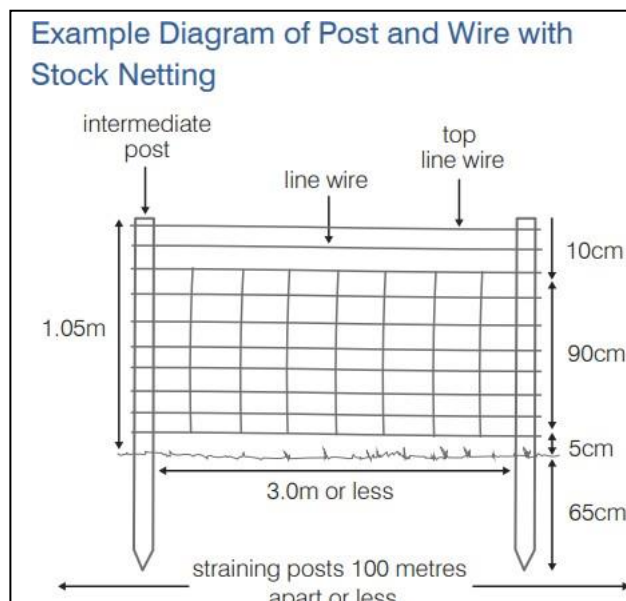

## SW07 - Timber Bridle Gate and Posts

These are the minimum standards of work required in order to be eligible to receive payments for 'Timber Bridle Gate and Posts'.

You must adhere to the following:

- Install Timber Bridle Gates and Posts constructed from either pressure treated softwood or hardwood.
- Install gates that are at least 1.5m wide and 1.3m high. Ensure there is sufficient space on one side of the gate for the horse to stand while the gate is being opened.
- Use a ready-made gate or construct a gate. All gate timbers must meet the following dimensions:
  - Uprights should be at least 10cm x 7.5cm in cross section.
  - All rails should be 7.5cm x 2.5cm in cross section except the top rail which should be 10cm x 7.5cm.
- Hang the gate so that it can be opened from both directions.
- Fit latches that allow the gate to be opened without the rider dismounting.
- Ensure that all post timbers must meet the following dimensions; – Hanging posts must be at least 15cm diameter – Shutting posts must be at least 12cm in diameter – Posts must be set into the ground to a sufficient depth to ensure stability.
- Ensure the gate is compliant with BS5709.



Do not:

- Install bridle gates and posts on Public Rights of Way (PRoW) unless approved by the Welsh Government.
- Use concrete to secure posts in the ground, as it can lead to rotting of the posts at ground level.

Requirements and guidance in addition to the specifications above:

- Use an 'extended' or a 'drop over' latch to allow the gate to be opened without the rider dismounting.
- In areas prone to vandalism, the top hook can be reversed to prevent the gate being lifted off.
- Best practice is to set the posts at least 70cm into the ground to ensure stability.

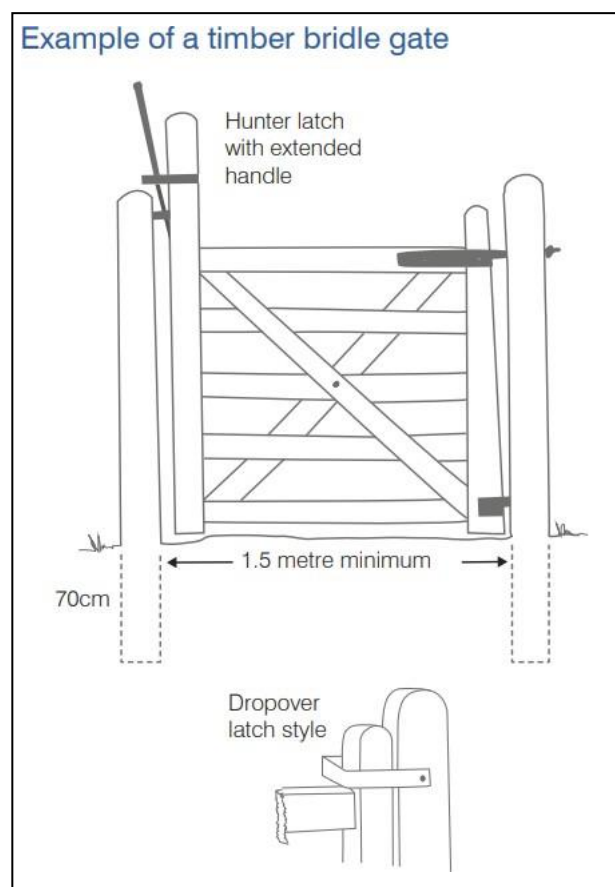

## SW08 - Timber Kissing Gate and Posts

These are the minimum standards of work required in order to receive payments for 'Timber Kissing Gate and Posts'. Kissing gates are used to allow walkers to cross field boundaries.

You must adhere to the following:

- Install Timber Kissing Gates and Posts constructed from either pressure treated softwood or hardwood.
- Install a kissing gate that is stock-proof with the gate in any position yet allowing free passage for pedestrians.
- Ensure that the kissing gate is an effective barrier against motorcycles and horses.
- Use a ready-made gate or construct a gate. All gates must meet the following dimensions;
- The gate must be 1.2m wide and 1.2m high.
- A 1m cylinder, must be able to pass through. Note that the 'throat' dimension (the narrowest space to pass through when the gate is opened) must be at least 1m.
- Ensure that post and rails meet the following dimensions;
  - Uprights should be at least 10cm x 7.5cm in cross section.
  - Rails should be 7.5cm x 2.5cm in cross section except the top rail which should be 10cm x 7.5cm.
  - Hanging posts must be at least 15cm diameter.
  - Shutting posts must be at least 12cm in diameter.
  - Posts must be set into the ground to a sufficient depth to ensure stability.
- Hang the gate so that the gate hooks are 'offset' by 3cm. This will cause the gate to close against one of the side posts when released.
- Ensure the gate is compliant with BS5709. The least restrictive furniture must be used as possible e.g. a gate is less restrictive than a stile.

Do not:

- Use concrete to secure posts in the ground, as it can lead to rotting of the posts at ground level.
- Use any barbed wire on the kissing gate.

Requirements and guidance in addition to the specifications above:

- For added protection against stock, a self-closing latch can be fitted.
- In areas prone to vandalism, the top hook can be reversed to prevent the gate being lifted off.
- Best practice is to set the posts at least 70cm into the ground to ensure stability

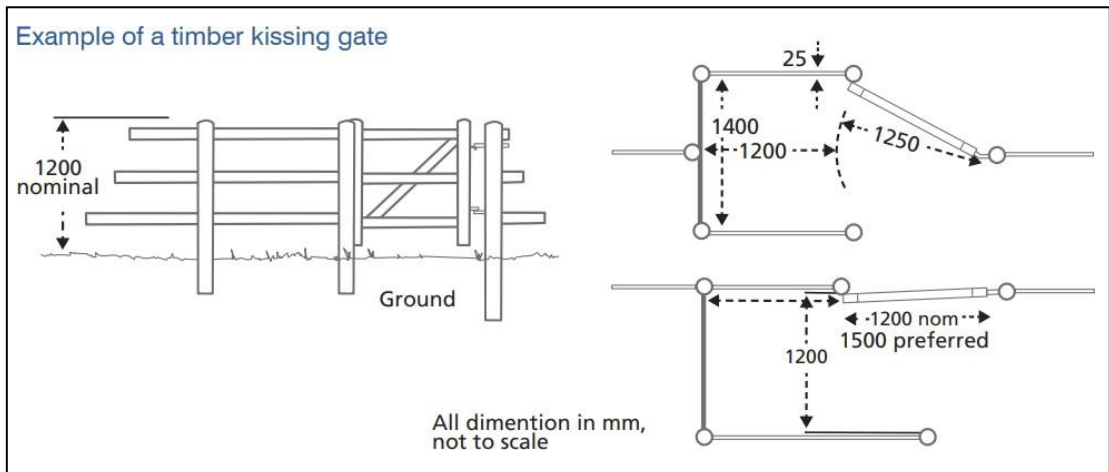

### SW13 - Deer fencing

These are the minimum standards of work required in order to be eligible to receive payments for deer fencing. Fencing timber must comprise either hardwood produced from Welsh woodlands or pressure treated softwood. A minimum life of 10 years is required for all timbers used. Trees and shrubs must not be used as strainers or fencing posts nor may they be used to support fencing wire, staples or netting.

Fencing timbers, line wire, netting and staples used to construct approved fence lines must always consist of new materials. The standard payments include an allowance for the dismantling, removal and safe disposal of existing derelict fences. All materials and construction standards must also conform to the following detailed specifications in addition to British Standards 1722 and 4102:

#### MATERIALS AND CONSTRUCTION – DEER FENCING

<b>Straining posts</b>	3m x 15cm top diameter minimum	10ft x 6"
<b>Struts</b>	2.75m x 10-13cm top diameter round timber	9ft x 4-5"
<b>Intermediate posts</b>	2.75m x 8-10cm top diameter round timber	9ft x 3-4"
<b>Netting</b>	Either High Tensile type Or Light Weight High Tensile type	HT/13/190/15 LHT/13/190/15
<b>Top wire</b>	1 x 12 ½ g high tensile plain wire	
<b>Line wire</b>	3 x 12 ½ g high tensile plain wire	
<b>Staples</b>	4cm (1 ½ ") 8g	
<b>Finished height</b>	1.9m – 2m (6ft4" – 6ft 6")	

## Construction

Strainer posts to be situated at change of direction (either horizontal or vertical) or maximum 200m (ca. 600ft) on straight run. Dug or driven a minimum 90cm (3ft) into the ground. The strainer struts to be notched and nailed to straining posts stabilised with a sawn rail thrust plate of 50cm x 38cm x 76cm (1ft 9" x 1½" x 3"). Intermediate to be spaced at 5m (16ft 6") intervals maximum.

The netting must be properly strained and fixed to give a maximum gap of 5cm (2") between the bottom of the net and the ground. A single top wire to be set 10cm (4") above the top of the netting. The line wires to be set such that the bottom strand runs along the bottom of the netting; the middle strand runs at a height of 1m (3ft 4") from ground level and the top strand to run along the top of the netting. All line wires to be fixed securely to the netting with pig rings or lashing rods.

## Diagram – D

